

第五章 射频滤波器设计

- 🏠 5.1 谐振器和滤波器的基本结构
- 🏠 5.2 特定滤波器的实现
- 🏠 5.3 微带线滤波器设计

5 射频滤波器设计

- ❖ 在射频/微波系统中通常**需要把信号频谱中有用的几个频率信号分离出来而滤除无用的其他频率信号**
- ❖ 完成这一功能的设备称为**滤波器 (Filter)**

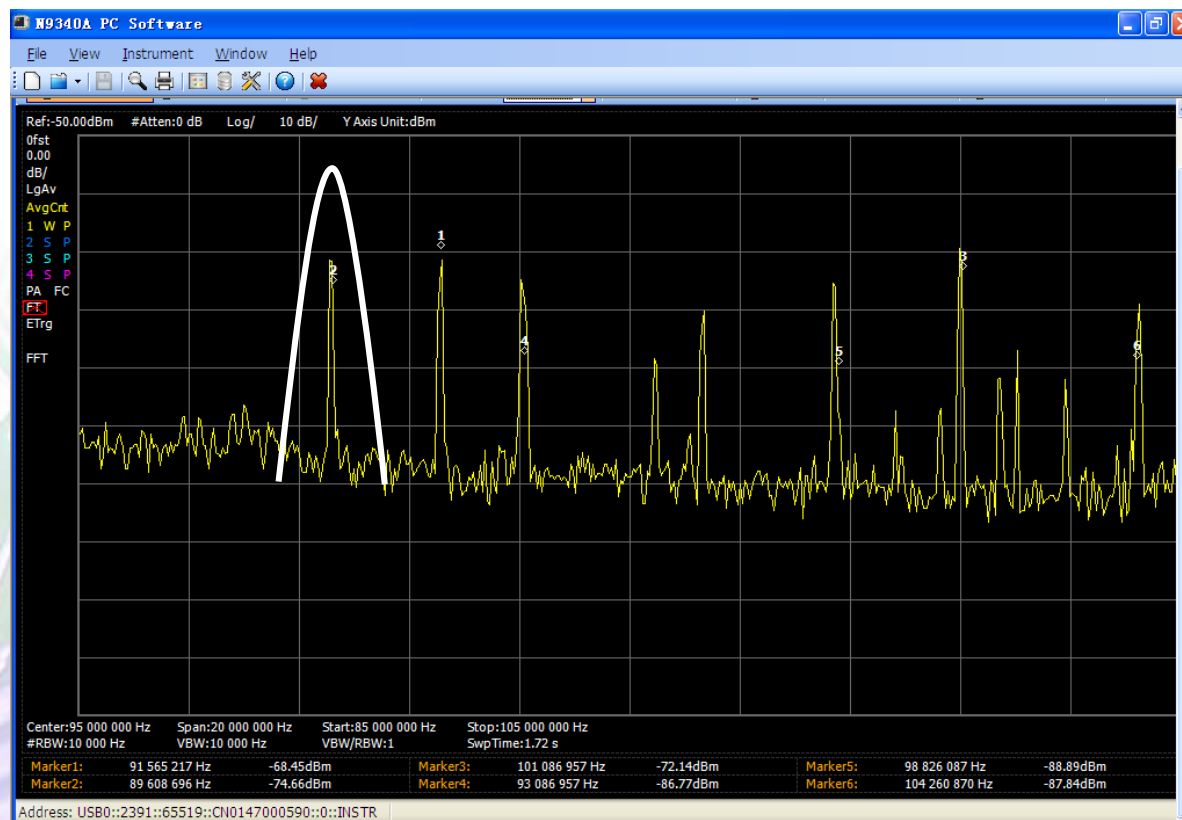

5 射频滤波器设计

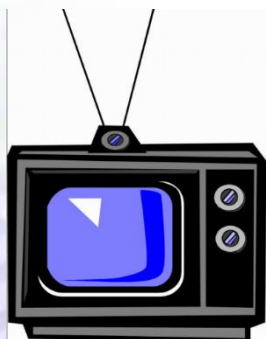

应用范围	频率范围
FM调频	88~106MHz
商用电视	54~890MHz
移动电话 (GSM)	900~1800MHz
微波炉	2.45GHz
全球卫星定位系统 (GPS)	1277MHz(军用) 1575MHz(民用)
无线局域网(WLAN)	2.4GHz或5.2GHz

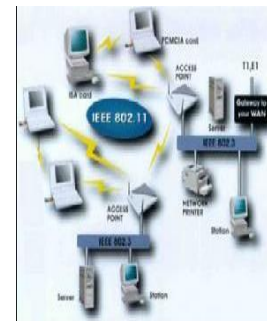
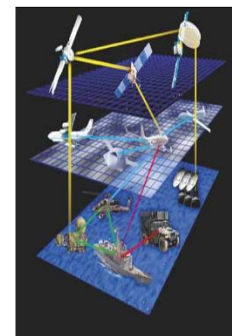

5 射频滤波器设计

在设计模拟电路时，对高频信号在特定频率或频段内的频率分量**做加重或衰减处理**是个十分重要的任务。

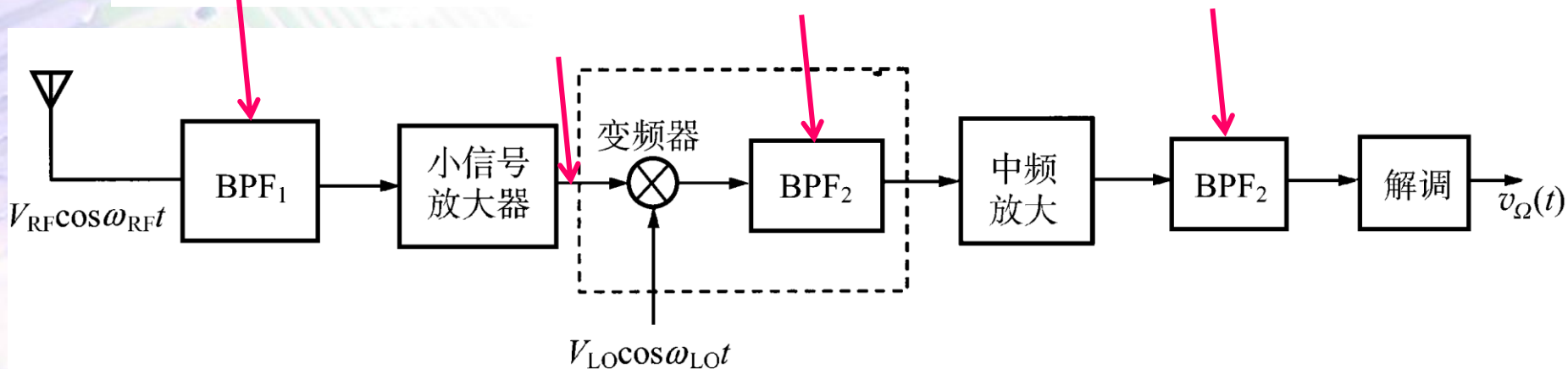
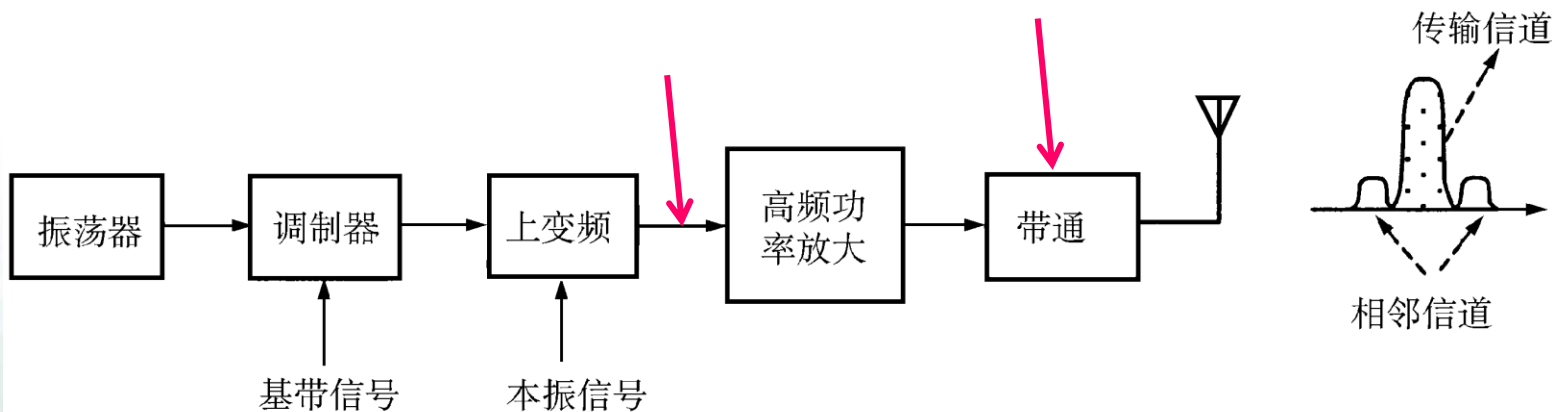

5 射频滤波器设计

$f_{RF} = 881 \text{ MHz}$
 $f_{IF1} = 45 \text{ MHz}$
 $f_{IF2} = 455 \text{ KHz}$

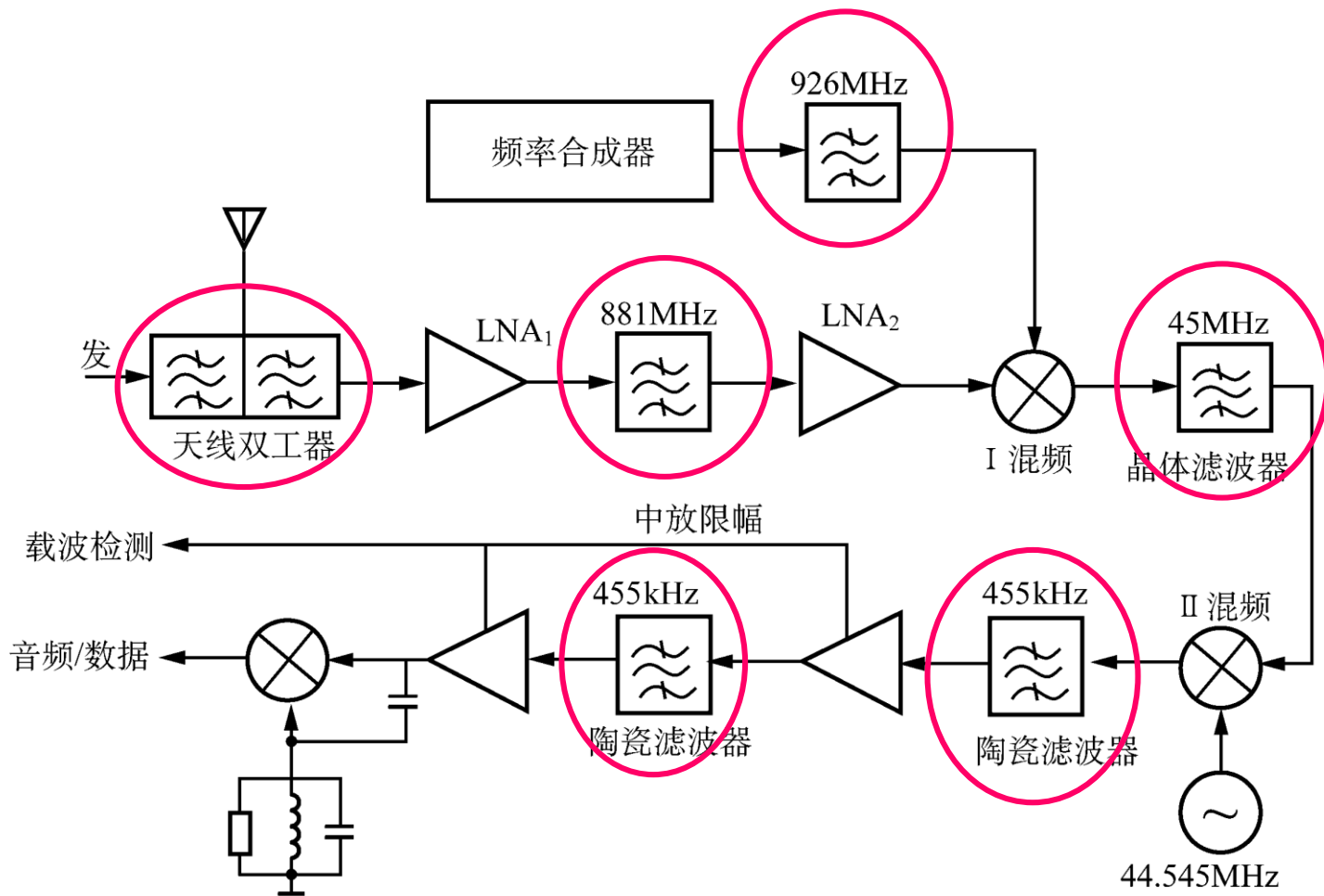

GSM 二次混频超外差接收机

5.1 谐振器和滤波器的基本结构

5.1.1 滤波器的类型和技术参数

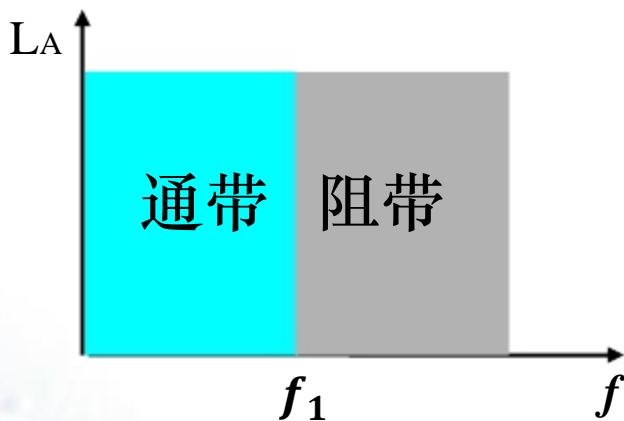

低通滤波器LPF

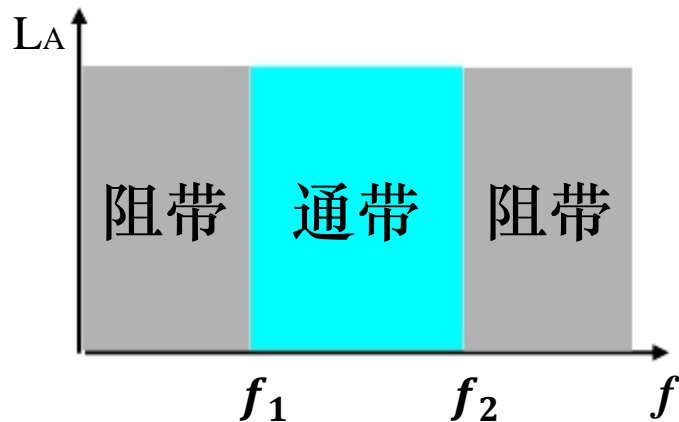

带通滤波器BPF

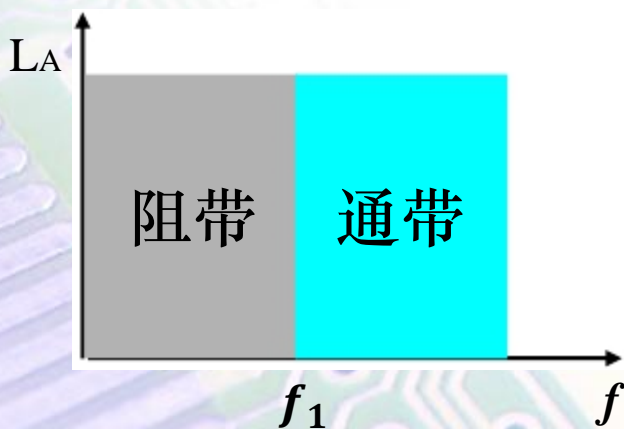

高通滤波器HPF

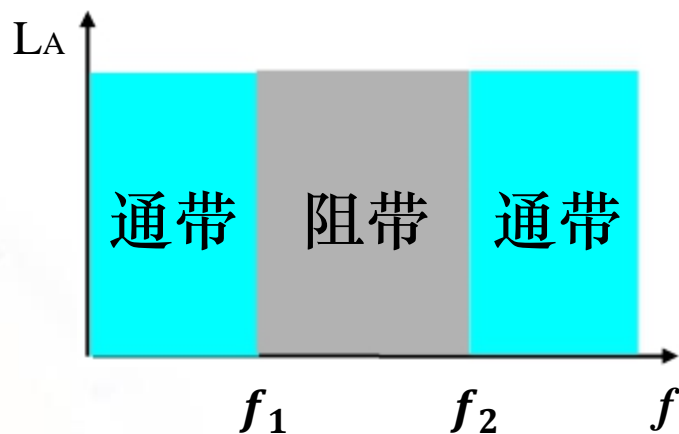

带阻滤波器BSF

5.1 谐振器和滤波器的基本结构

理想的滤波特性用有限个元件无法实现，因此，实际的滤波器只能逼近理想滤波器的衰减特性。

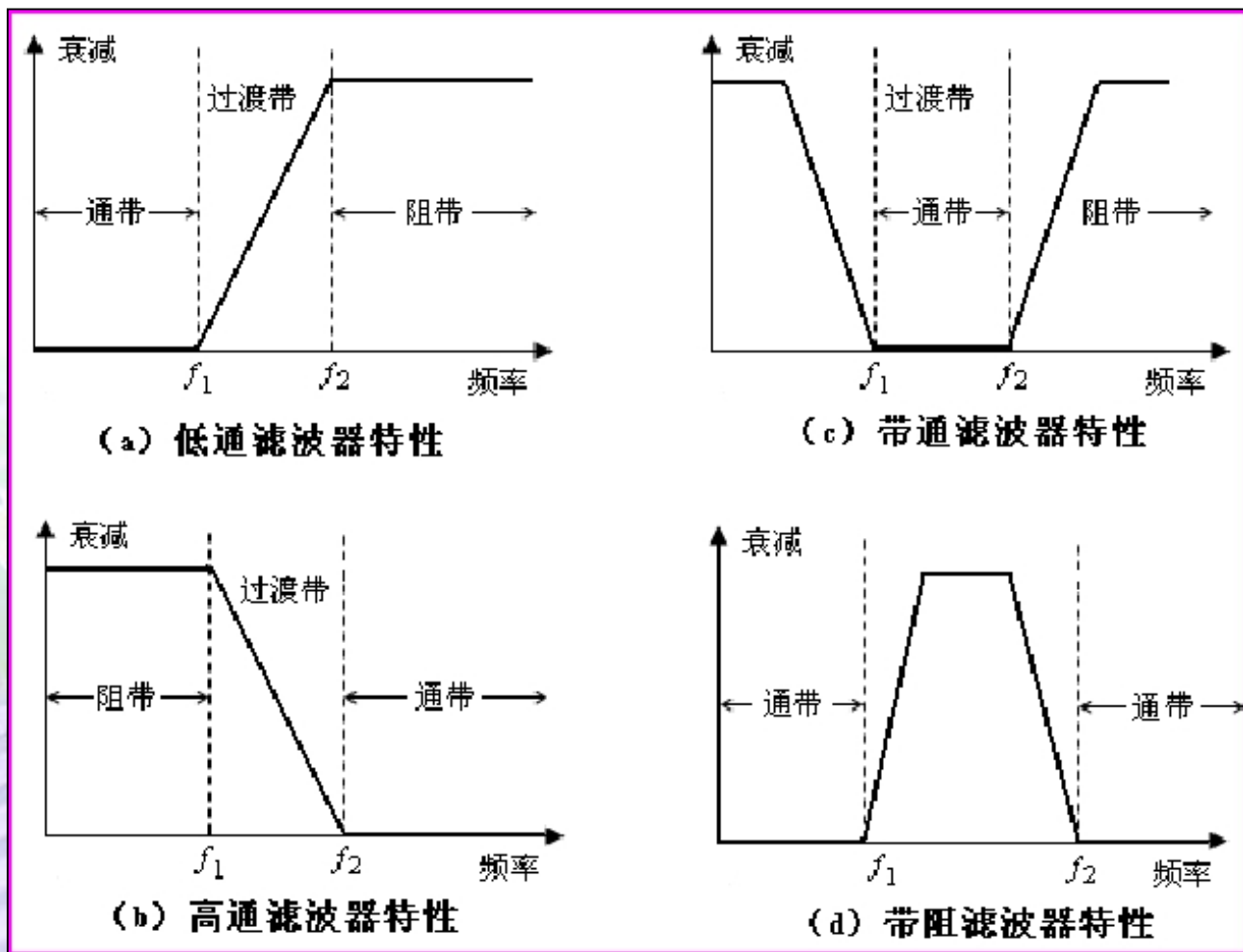

5.1 谐振器和滤波器的基本结构

5.1.1 滤波器的类型和技术参数

- **RF 插入损耗**：定量描述了功率响应与0dB基准的差值，即：

$$IL = 10 \log \frac{P_A}{P_L} = -10 \log (1 - |\Gamma_{in}|^2)$$

- **波纹**：通带内信号的平坦度。
- **带宽**：通带内对应3dB 频率。
- **矩形系数**：60dB与3dB带宽的比值。它反映了曲线的陡峭程度。
- **阻带抑制**：常以60dB为设计值

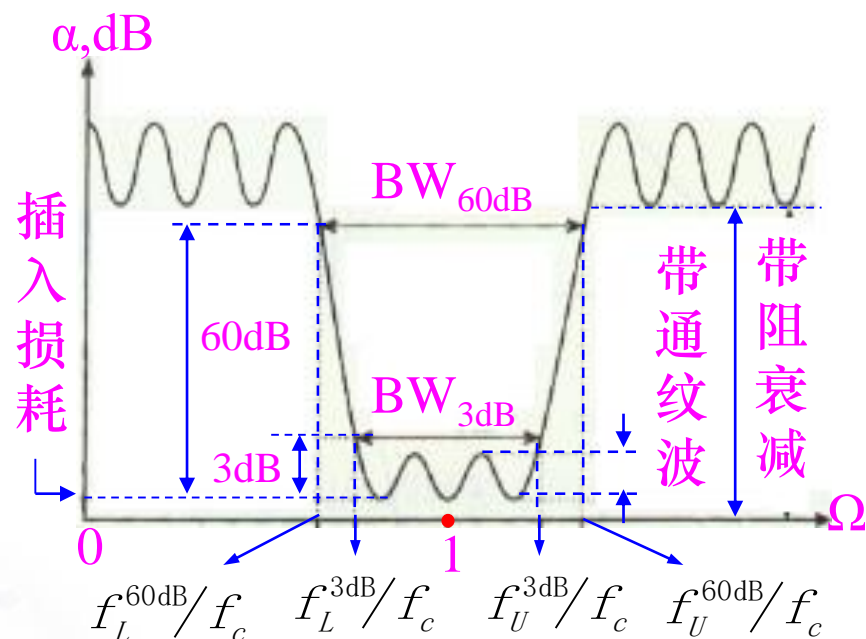

5.1 谐振器和滤波器的基本结构

三种低通滤波器的实际衰减曲线

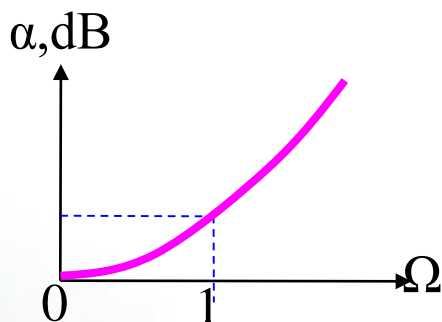

二项式滤波器

具有**单调的衰减**曲线，一般比较容易实现。若想在通带和阻带之间实现陡峭变化，需使用很多元件。

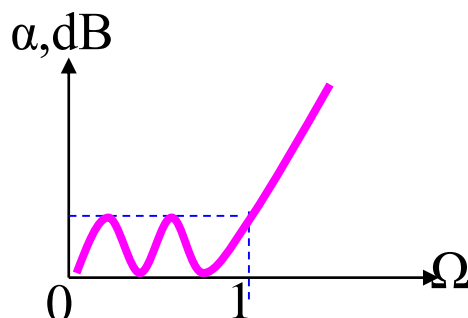

切比雪夫滤波器

在通带或阻带内保持**相等的波纹幅度**，则可得到较好的**陡峭过渡衰减**曲线。

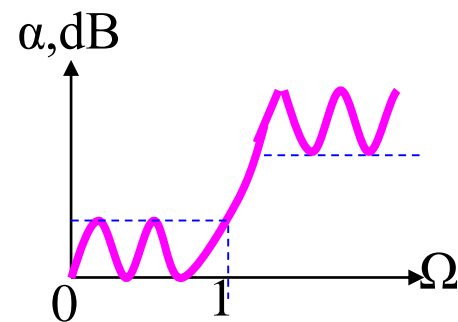

椭圆函数滤波器

衰减曲线**最陡峭**，但代价是其通带和阻带内均有波纹。

5.1 谐振器和滤波器的基本结构

5.1.2 低通滤波器

图为一阶低通滤波器，
设 $Z_G=R_G$ ， $Z_L=R_L$ ，用四个
级连ABCD参量网络构成。

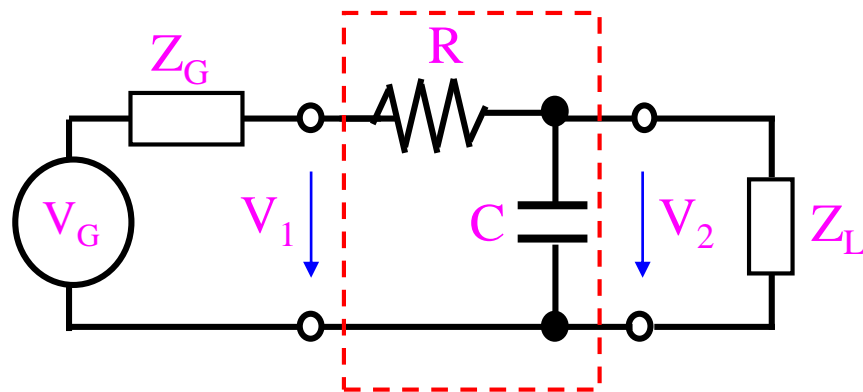

$$\begin{bmatrix} A & B \\ C & D \end{bmatrix} = \begin{bmatrix} 1 & R_G \\ 0 & 1 \end{bmatrix} \begin{bmatrix} 1 & R \\ 0 & 1 \end{bmatrix} \begin{bmatrix} 1 & 0 \\ j\omega C & 1 \end{bmatrix} \begin{bmatrix} 1 & 0 \\ 1/R_L & 1 \end{bmatrix} = \begin{bmatrix} 1 + (R + R_G)(j\omega C + 1/R_L) & R_G + R_L \\ j\omega C + 1/R_L & 1 \end{bmatrix}$$

故：
$$\frac{V_2}{V_G} = \frac{1}{A} = \frac{1}{1 + (R + R_G)(j\omega C + 1/R_L)}$$

当 $\omega \rightarrow 0$ 时：
$$\frac{V_2}{V_G} = \frac{R_L}{R_G + R + R_L}$$
 当 $\omega \rightarrow \infty$ 时：
$$\frac{V_2}{V_G} = 0$$
 具有低通特征

当 $R_L \rightarrow \infty$ 时：
$$\frac{V_2}{V_G} = H(\omega) = \frac{1}{1 + j\omega(R_G + R)C}$$
 为纯一阶系统， $H(\omega)$ 为传递函数

5.1 谐振器和滤波器的基本结构

$$H(\omega) = \frac{1}{1 + (R + R_G)(j\omega C + 1/R_L)}$$

衰减系数: $\alpha(\omega) = -\ln |H(\omega)| = -20 \log |H(\omega)|$

相位关系: $\varphi(\omega) = \arctan \frac{\text{Im} |H(\omega)|}{\text{Re} |H(\omega)|}$

群时延: $t_g = \frac{d\varphi(\omega)}{d\omega}$

我们经常需要设计具有**线性相位** ($\varphi = -A\omega$) 的滤波器, 即 $t_g = A$

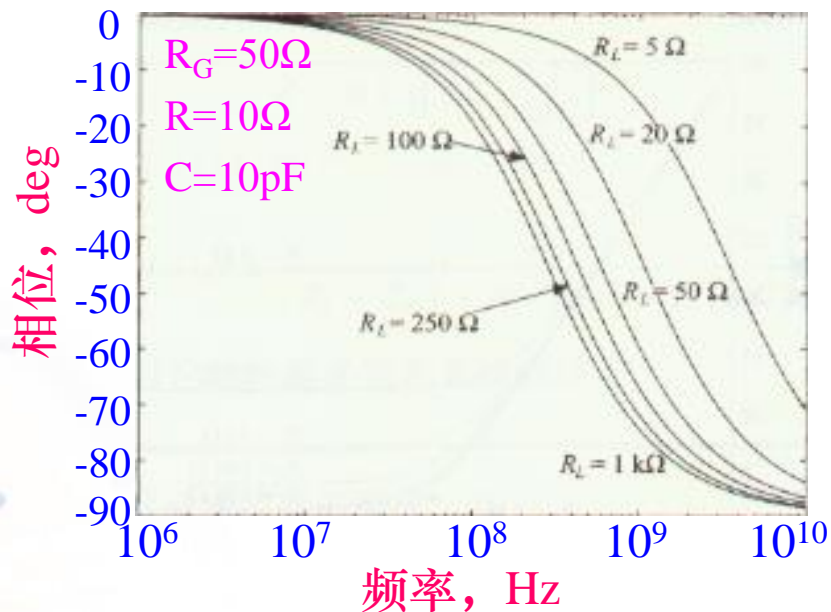
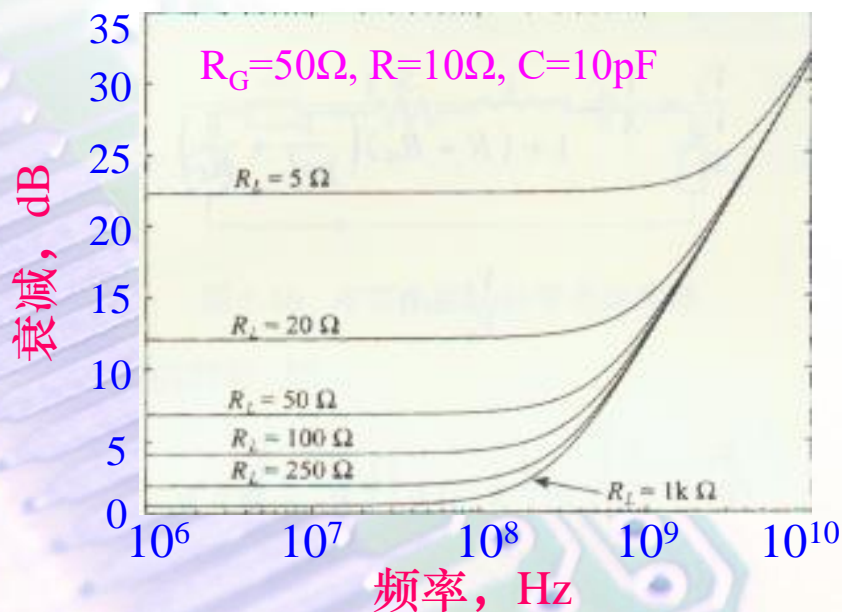

5.1 谐振器和滤波器的基本结构

5.1.3 高通滤波器

图为一阶高通滤波器，设 $Z_G=R_G$ ， $Z_L=R_L$ ，用四个级连 ABCD 参量网络构成。

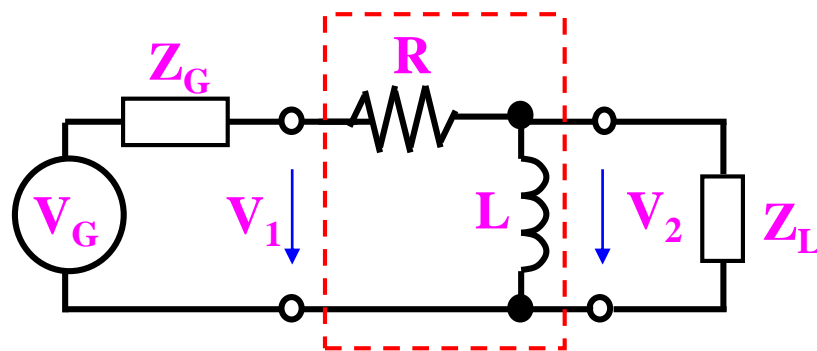

$$\begin{bmatrix} A & B \\ C & D \end{bmatrix} = \begin{bmatrix} 1 & R_G \\ 0 & 1 \end{bmatrix} \begin{bmatrix} 1 & R \\ 0 & 1 \end{bmatrix} \begin{bmatrix} 1 & 0 \\ \frac{1}{j\omega L} & 1 \end{bmatrix} \begin{bmatrix} 1 & 0 \\ \frac{1}{R_L} & 1 \end{bmatrix} = \begin{bmatrix} 1 + (R + R_G) \left(\frac{1}{j\omega L} + \frac{1}{R_L} \right) & R_G + R_L \\ \frac{1}{j\omega L} + \frac{1}{R_L} & 1 \end{bmatrix}$$

故：
$$\frac{V_2}{V_G} = \frac{1}{A} = \frac{1}{1 + (R + R_G) \left(\frac{1}{j\omega L} + \frac{1}{R_L} \right)}$$

当 $\omega \rightarrow 0$ 时：
$$\frac{V_2}{V_G} = 0$$

当 $\omega \rightarrow \infty$ 时：
$$\frac{V_2}{V_G} = \frac{R_L}{R_G + R + R_L}$$

⇒ 高通

5.1 谐振器和滤波器的基本结构

$$H(\omega) = \frac{1}{1 + (R + R_G) \left(\frac{1}{j\omega L} + \frac{1}{R_L} \right)}$$

$R_G = 50\Omega$, $R = 10\Omega$, $L = 100\text{nH}$

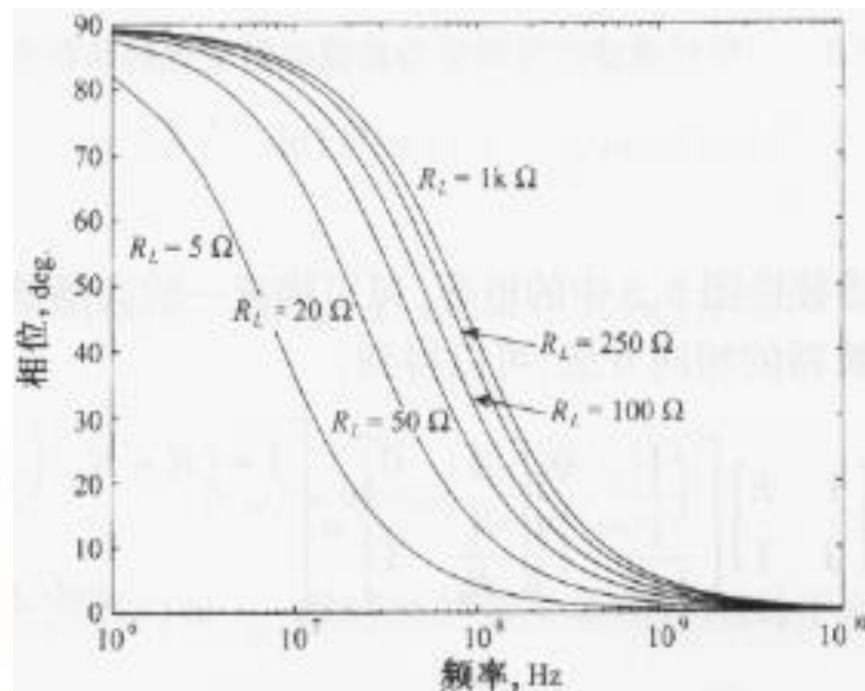
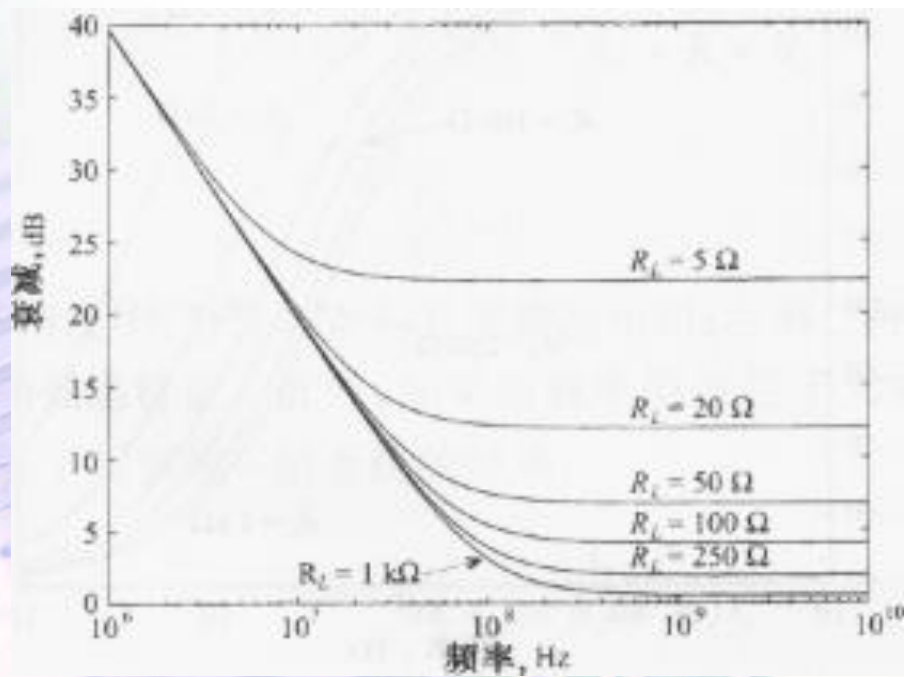

5.1 谐振器和滤波器的基本结构

5.1.4 带通和带阻滤波器

带通滤波器可采用RLC串联或并联电路结构。对串联电路：

$$Z = R + j(\omega L - 1/\omega C)$$

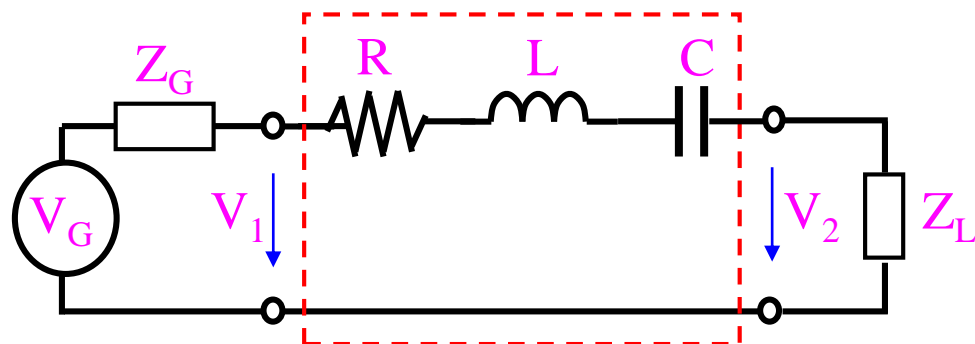

$$\text{则: } \begin{bmatrix} A & B \\ C & D \end{bmatrix} = \begin{bmatrix} 1 & Z_G \\ 0 & 1 \end{bmatrix} \begin{bmatrix} 1 & Z \\ 0 & 1 \end{bmatrix} \begin{bmatrix} 1 & 0 \\ 1/Z_L & 1 \end{bmatrix} = \begin{bmatrix} 1 + (Z + Z_G)/Z_L & Z_G + Z \\ 1/Z_L & 1 \end{bmatrix}$$

传递函数：

$$\frac{V_2}{V_G} = H(\omega) = \frac{Z_L}{Z_L + (Z + Z_G)} = \frac{Z_L}{Z_L + Z_G + R + j[\omega L - 1/(\omega C)]}$$

5.1 谐振器和滤波器的基本结构

例5.1 设 $Z_L=Z_G=50\Omega$, $L=5\text{nH}$, $R=20\Omega$, $C=2\text{pF}$, 求滤波器的频率响应。

$$H(\omega) = \frac{Z_L}{Z_L + Z_G + R + j[\omega L - 1/(\omega C)]}$$

解:

$$\alpha(\omega) = -20\log \left| \frac{50}{120 + j(10\pi f \times 10^{-9} - 10^{12}/4\pi f)} \right|$$

$$\varphi(\omega) = \arctan \frac{\text{Im}|H(\omega)|}{\text{Re}|H(\omega)|}$$

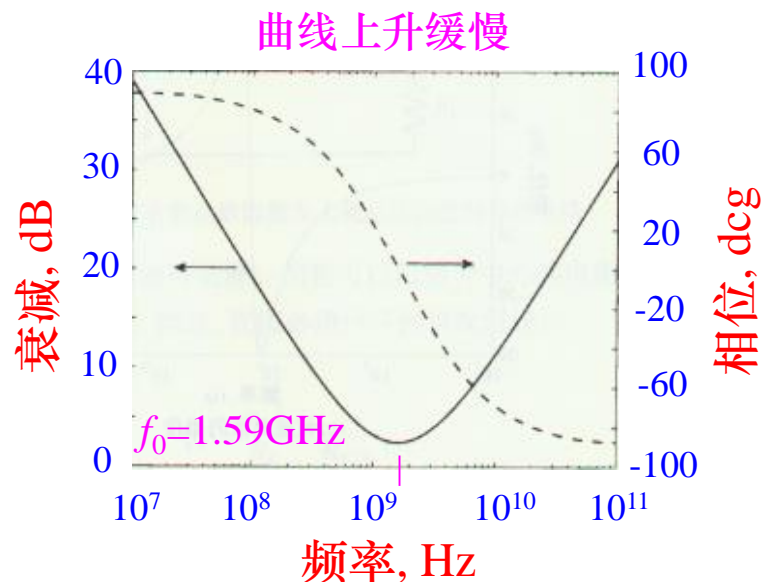

对并联电路: $Z = 1/Y$, $Y = G + j(\omega C - 1/\omega L)$

此处为带阻滤波器

则传递函数: $\frac{V_2}{V_G} = H(\omega) = \frac{Z_L}{Z_L + (1/Y + Z_G)} = \frac{Z_L [G + j(\omega C - 1/\omega L)]}{(Z_L + Z_G) [G + j(\omega C - 1/\omega L)] + 1}$

5.1 谐振器和滤波器的基本结构

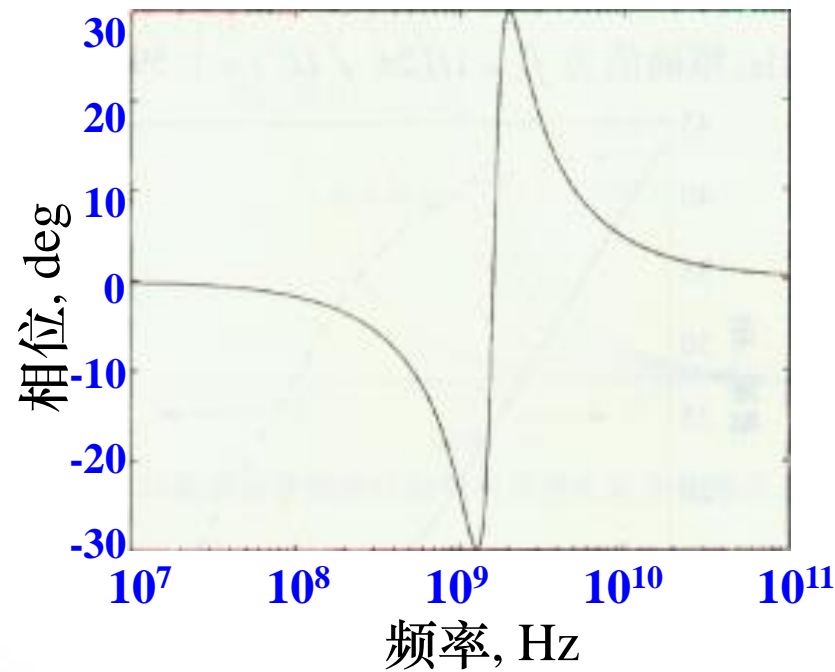
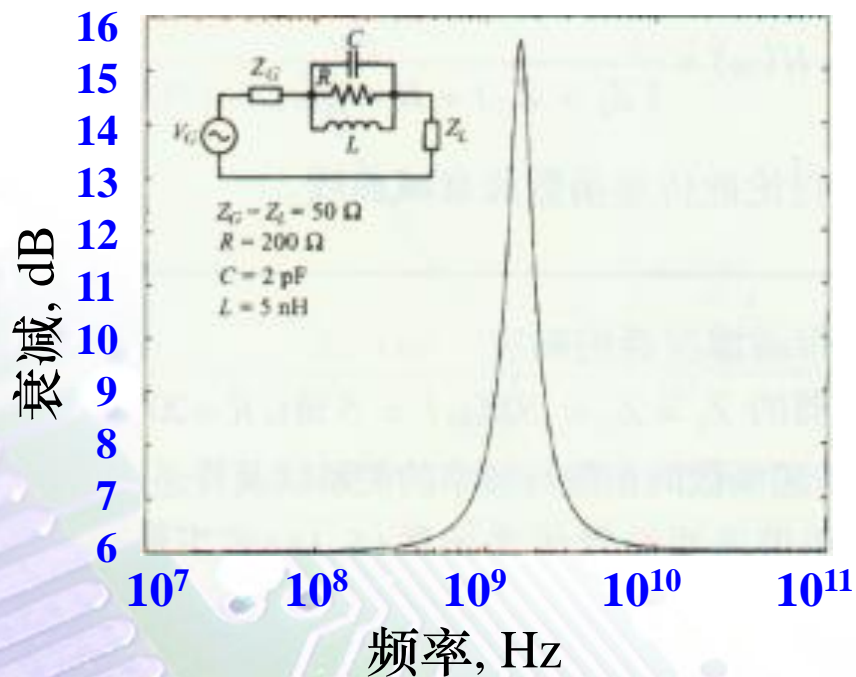

RLC串联电路换成并联电路以后，则带通电路变成带阻电路，其衰減曲线要陡峭得多。

5.1 谐振器和滤波器的基本结构

当 $\omega L = \frac{1}{\omega C}$ 时电路发生串联谐振，其谐振频率：

$$\omega_0 = \frac{1}{\sqrt{LC}}$$

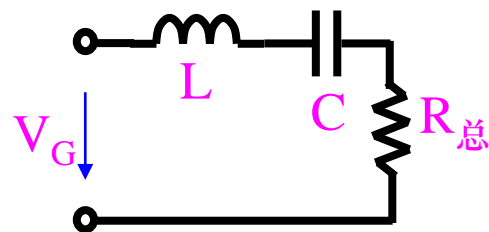

$$H(\omega) = \frac{Z_L}{Z_L + Z_G + R + j[\omega L - 1/(\omega C)]}$$

由带宽定义： $|H(\omega)| = \left| \frac{R_{\text{总}}}{R_{\text{总}} + j(\omega L - 1/\omega C)} \right| = \frac{1}{\sqrt{1 + \left(\frac{\omega L}{R_{\text{总}}} - \frac{1}{\omega C R_{\text{总}}} \right)^2}} = \frac{1}{\sqrt{2}}$

$$Q = \frac{\omega_0 L}{R_{\text{总}}} = \frac{1}{\omega_0 C R_{\text{总}}}$$

即： $Q \left(\frac{\omega}{\omega_0} - \frac{\omega_0}{\omega} \right) = Q \frac{(\omega + \omega_0)(\omega - \omega_0)}{\omega_0 \omega} \approx Q \frac{2(\omega - \omega_0)}{\omega_0} = \pm 1$

故： $f_U^{3\text{dB}} = f_0 + \frac{f_0}{2Q}$, $f_L^{3\text{dB}} = f_0 - \frac{f_0}{2Q}$, $\text{BW} = \frac{f_0}{Q}$

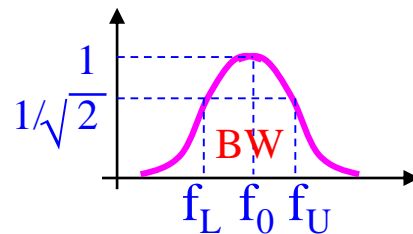

5.1 谐振器和滤波器的基本结构

外部品质因素($R_E = R_G + R_L \neq 0, R = 0$):

$$Q_E = \frac{\omega_0 L}{R_E} = \frac{1}{R_E \omega_0 C}$$

固有品质因素($R_E = R_G + R_L = 0, R \neq 0$):

$$Q_F = \frac{\omega_0 L}{R} = \frac{1}{R \omega_0 C}$$

有载品质因素($R_E = R_G + R_L \neq 0, R \neq 0$):

$$Q_{LD} = \frac{\omega_0 L}{R + R_E} = \frac{1}{(R + R_E) \omega_0 C}$$

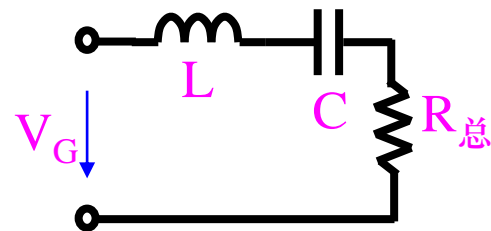

$$H(\omega) = \frac{Z_L}{Z_L + Z_G + R + j[\omega L - 1/(\omega C)]}$$

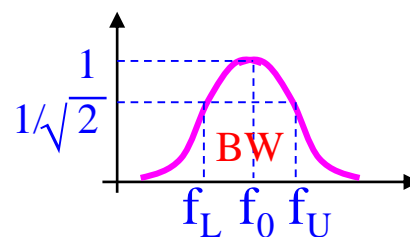

将串联公式中
 $R \rightarrow G, L \rightarrow C$
 $C \rightarrow L, V \rightarrow I$
可得并联公式

5.1 谐振器和滤波器的基本结构

5.1.5 插入损耗

采用网络分析仪测量 Q 值比测量阻抗或导纳更容易，对串联谐振器：

$$Z = R + j\left(\omega L - \frac{1}{\omega C}\right) = (R_E + R) \left[\frac{R}{R_E + R} + j\left(\frac{\omega L}{R_E + R} - \frac{1}{\omega C(R_E + R)}\right) \right]$$
$$= (R_E + R) \left[\frac{Q_{LD}}{Q_F} + jQ_{LD}\varepsilon \right]$$

并联谐振器： $Y = (G_E + G) \left[\frac{Q_{LD}}{Q_F} + jQ_{LD}\varepsilon \right]$ ，其中 $\varepsilon = \left(\frac{\omega}{\omega_0} - \frac{\omega_0}{\omega}\right)$ 称为归一化频率偏差。

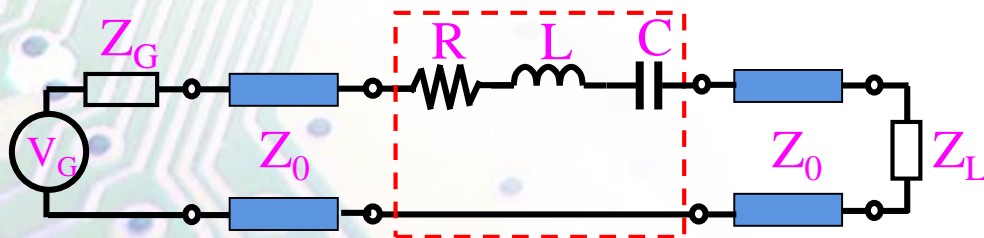

5.1 谐振器和滤波器的基本结构

设传输线在信号端和负载端均处于匹配状态($Z_L = Z_G = Z_0$)

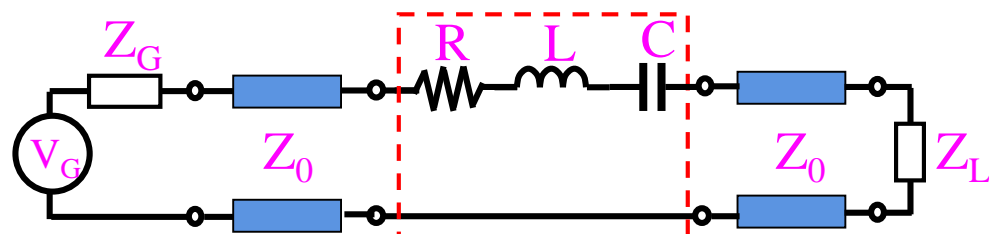

不插滤波器: $P_L = P_{in} = |V_G|^2 / 8Z_0$

$$\text{插滤波器后: } P_L = \frac{1}{2} \left| \frac{V_G}{2Z_0 + Z} \right|^2 Z_0 = \frac{|V_G|^2 / (8Z_0)}{\frac{1}{4Z_0^2} \left| 2Z_0 + (2Z_0 + R) \left[\frac{Q_{LD}}{Q_F} + j\varepsilon Q_{LD} \right] \right|^2}$$

$$= \frac{P_{in}}{(1 + \varepsilon^2 Q_{LD}^2) \frac{Q_E^2}{Q_{LD}^2}}$$

$$\frac{1}{Q_F} = \frac{1}{Q_{LD}} - \frac{1}{Q_E}$$

$$2Z_0 = R_G + R_L = R_E$$

则插入损耗:

$$IL = 10 \log \frac{P_{in}}{P_L} = 10 \log \frac{1 + \varepsilon^2 Q_{LD}^2}{Q_{LD}^2 / Q_E^2} = 10 \log (1 + \varepsilon^2 Q_{LD}^2) - 10 \log \left(1 - \frac{Q_{LD}}{Q_F} \right)^2$$

在谐振状态下, $\varepsilon = 0$, 第一项没有影响; 当滤波器偏离谐振时影响明显。

5.1 谐振器和滤波器的基本结构

插入损耗:

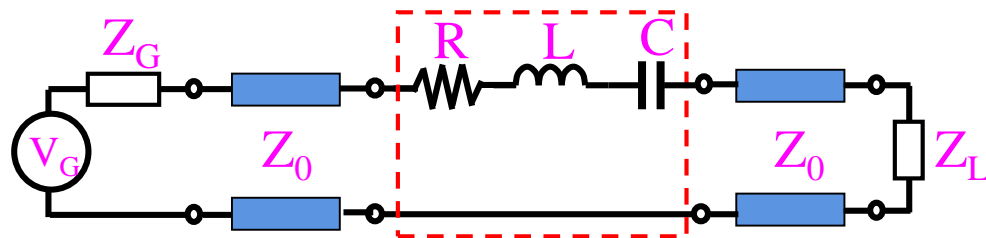

$$\text{IL} = 10 \log \frac{P_{in}}{P_L} = 10 \log \frac{1 + \varepsilon^2 Q_{LD}^2}{Q_{LD}^2 / Q_E^2} = 10 \log (1 + \varepsilon^2 Q_{LD}^2) - 10 \log \left(1 - \frac{Q_{LD}}{Q_F} \right)^2$$

由 $\text{IL} = -10 \log (1 - |\Gamma_{in}|^2)$

$$1 - |\Gamma_{in}|^2 = 1 - \left| \frac{Z_{in} - Z_0}{Z_{in} + Z_0} \right|^2 = \frac{Q_{LD}^2 / Q_E^2}{1 + \varepsilon^2 Q_{LD}^2} = \frac{1}{\text{LF}}$$

其中LF称为**损耗因子**，是设计滤波器衰减特性的关键参数。

5.1 谐振器和滤波器的基本结构

例5.2 右图中 $Z_0 = Z_L = Z_G = 50\Omega$,
 $R = 10\Omega$, $L = 50\text{nH}$, $C = 0.47\text{pF}$,
 $V_G = 5\text{V}$, 求各种品质因数及信号源
 输出功率和谐振状态下负载吸收功率。

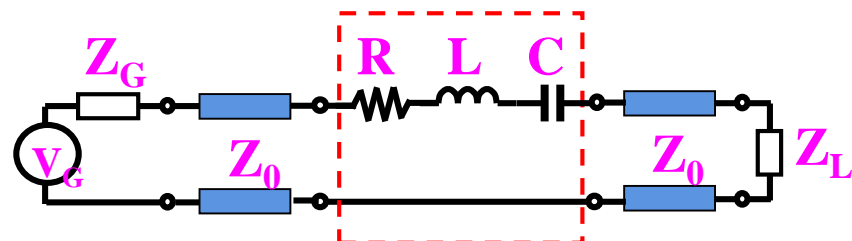

解: $f_0 = \frac{1}{2\pi\sqrt{LC}} = 1.038\text{GHz}$

$$Q_E = \frac{\omega_0 L}{2Z_0} = 3.26 \quad Q_F = \frac{\omega_0 L}{R} = 32.62$$

$$Q_{LD} = \frac{\omega_0 L}{R + 2Z_0} = 2.97$$

$$P_{in} = |V_G|^2 / (8Z_0) = 62.5\text{mW}$$

$$P_L = \frac{P_{in}}{(1 + \epsilon^2 Q_{LD}^2) Q_E^2 / Q_{LD}^2} \Big|_{f=f_0} = \frac{P_{in}}{Q_E^2 / Q_{LD}^2} = 51.7\text{mW}$$

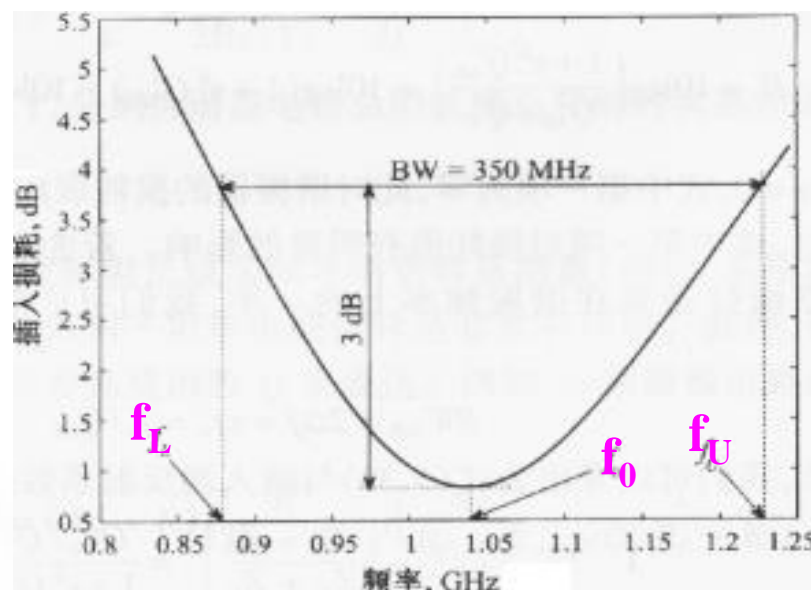

5.2 特定滤波器的实现

5.2.1 巴特沃斯滤波器

衰减曲线没有任何纹波，称为**最大平滑滤波器**。

低通： $IL = -10\log(1 - |\Gamma_{in}|^2) = 10\log\{LF\} = 10\log\{1 + a^2\Omega^{2N}\}$

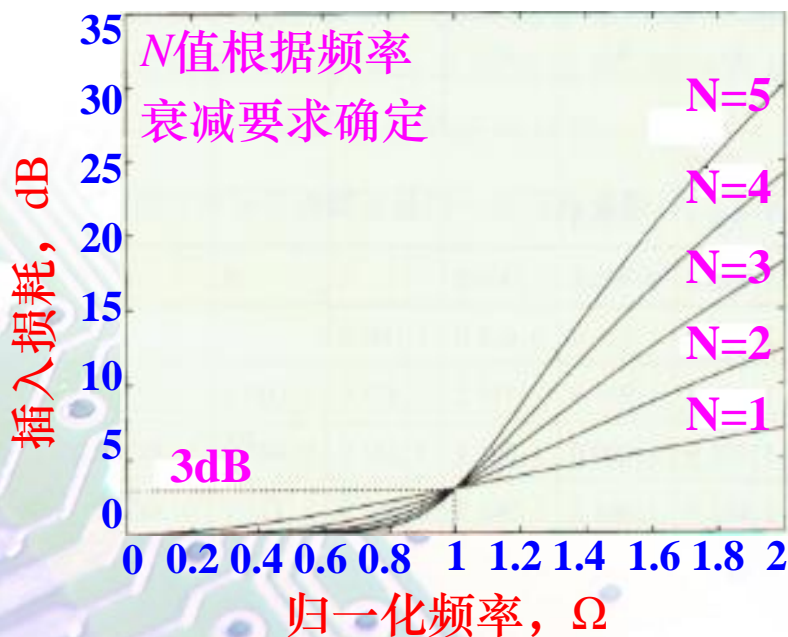

N 为滤波器的阶数，
通常 $a=1$ ，当 $\Omega=1$ 时，
 $IL=3\text{dB}$ 为截止频率点

5.2 特定滤波器的实现

两种结构:

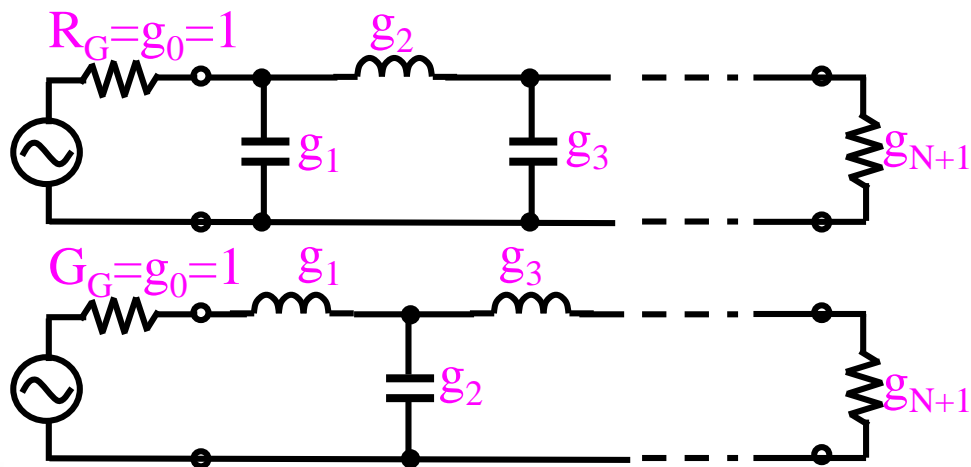

其中 g_0 为波源内电阻或内电导,

g_m 为电感或电容值, g_{N+1} 为负载电阻或电导值, 所有 g 值都有表可查。

表5.2 最大平滑低通滤波器归一化元件参数

N	g_1	g_2	g_3	g_4	g_5	g_6	g_7	g_8	g_9	g_{10}	g_{11}
1	2.0000	1.0000									
2	1.4142	1.4142	1.0000								
3	1.0000	2.0000	1.0000	1.0000							
4	0.7654	1.8478	1.8478	0.7654	1.0000						
5	0.6180	1.6180	2.0000	1.6180	0.6180	1.0000					
6	0.5176	1.4142	1.9318	1.9318	1.4142	0.5176	1.0000				
7	0.4450	1.2470	1.8019	2.0000	1.8019	1.2470	0.4450	1.0000			
8	0.3902	1.1111	1.6629	1.9615	1.9615	1.6629	1.1111	0.3902	1.0000		
9	0.3473	1.0000	1.5321	1.8794	2.0000	1.8794	1.5321	1.0000	0.3473	1.0000	
10	0.3129	0.9080	1.4142	1.7820	1.9754	1.9754	1.7820	1.4142	0.9080	0.3129	1.0000

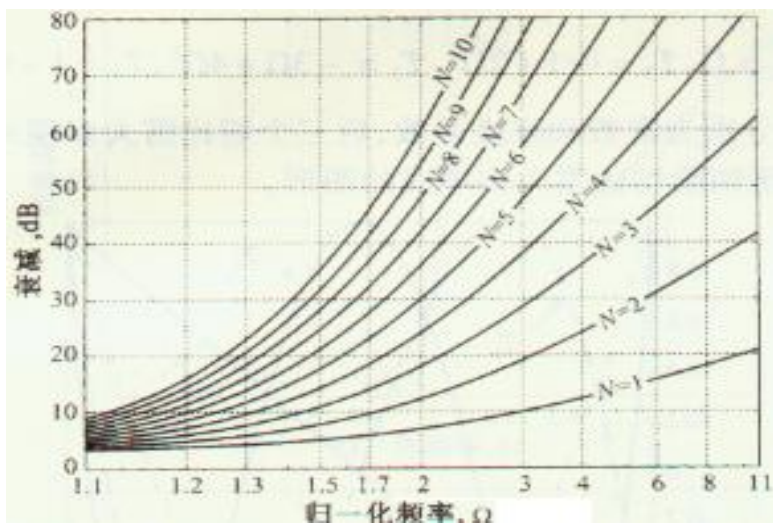

- 对于不同的 N ，从图中可找到滤波器衰减与频率的对应关系。如 $\Omega=2$ ， $\alpha=60\text{dB}$ ， $N=10$ 。
- 线性相移和陡峭的幅度变化相互冲突

5.2 特定滤波器的实现

5.2.2 切比雪夫滤波器

对于低通：

$$\text{IL} = 10 \log \{LF\} = 10 \log \{1 + a^2 T_N^2(\Omega)\}$$

其中

$$|\Omega| \leq 1: T_N(\Omega) = \cos \left\{ N \left[\cos^{-1}(\Omega) \right] \right\}$$

$$|\Omega| \geq 1: T_N(\Omega) = \cosh \left\{ N \left[\cosh^{-1}(\Omega) \right] \right\}$$

$$|\Omega| \leq 1 \text{ 时, } T_0 = 1, T_1 = \Omega, T_2 = -1 + 2\Omega^2,$$

$$T_3 = -3\Omega + 4\Omega^3, T_4 = 1 - 8\Omega^2 + 8\Omega^4, \dots$$

显然，波纹曲线均在 ± 1 之间振荡。

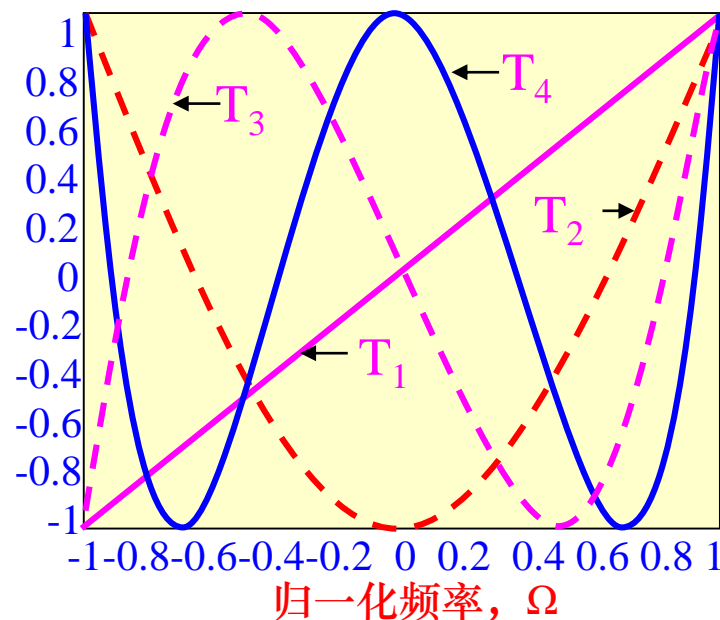

5.2 特定滤波器的实现

低通: $IL = 10\log\{LF\} = 10\log\{1 + a^2 T_N^2(\Omega)\}$

当 $a=1$, $\Omega=1$ 时:

$$IL = 10\log\{1+1\} = 3\text{dB}$$

通带内各点的衰减均在3dB以下, 要减小波纹的幅度可适当通过选择系数 a 来控制。

若纹波峰值为 RPL_{dB} , 则由插入损耗:

$$a = \sqrt{10^{RPL_{\text{dB}}/10} - 1}$$



表5.4(a) 切比雪夫滤波器元件参数 (3dB纹波)

N	g_1	g_2	g_3	g_4	g_5	g_6	g_7	g_8	g_9	g_{10}	g_{11}
1	1.9953	1.0000									
2	3.1013	0.5339	5.8095								
3	3.3487	0.7117	3.3487	1.0000							
4	3.4389	0.7483	4.3471	0.5920	5.8095						
5	3.4817	0.7618	4.5381	0.7618	3.4817	1.0000					
6	3.5045	0.7865	4.6061	0.7929	4.4641	0.6033	5.8095				
7	3.5182	0.7723	4.6386	0.8039	4.6386	0.7723	3.5182	1.0000			
8	3.5277	0.7745	4.6575	0.8089	4.6990	0.8018	4.4990	0.6073	5.8095		
9	3.5340	0.7760	4.6692	0.8118	4.7272	0.8118	4.6692	0.7760	3.5340	1.0000	
10	3.5384	0.7771	4.6768	0.8136	4.7425	0.8164	4.7260	0.8051	4.5142	0.6091	5.8095

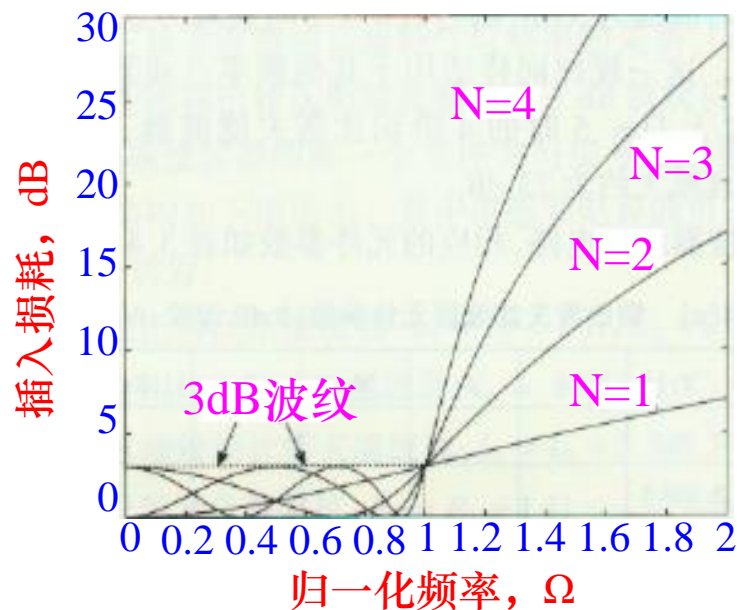
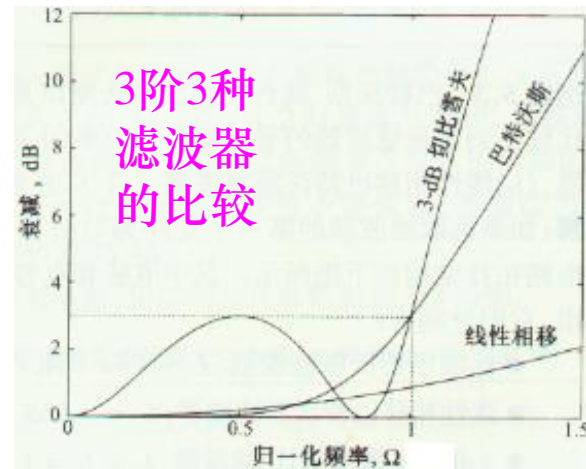
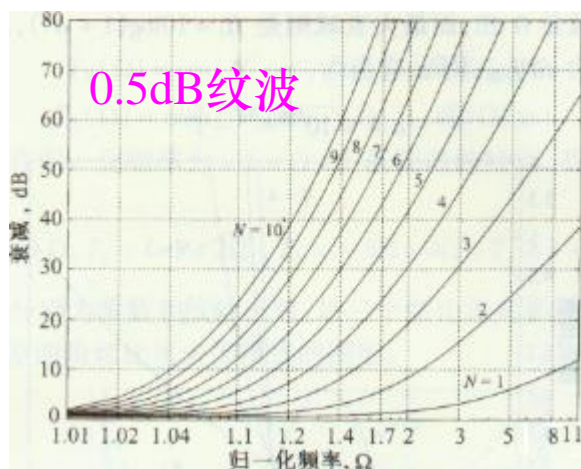
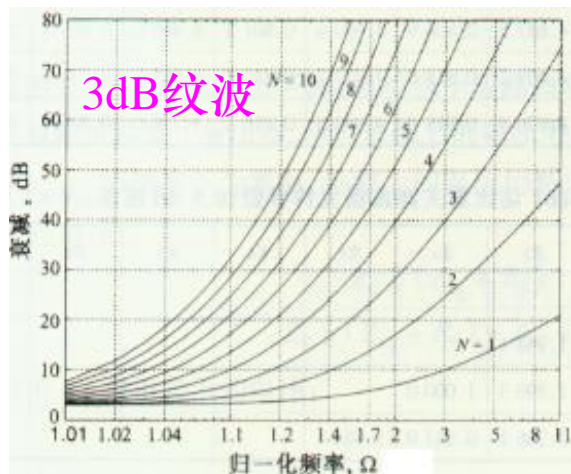

5.2.3 标准低通滤波器的反归一化

以满足实际工作频率和阻抗的要求，并根据标准原型低通变为高通、带通或带阻滤波器。

1. 频率变换：将归一化频率 Ω 变换为实际频率 ω ，并按比例调整标准电感和标准电容。

对低通滤波器： $\omega = \Omega\omega_c$

归一化电抗：

$$jX_L = j\Omega L = j(\omega / \omega_c)L = j\omega\tilde{L}$$

实际电感： $\tilde{L} = L / \omega_c$

$$jX_C = \frac{1}{j\Omega C} = \frac{1}{j(\omega / \omega_c)C} = \frac{1}{j\omega\tilde{C}}$$

实际电容： $\tilde{C} = C / \omega_c$

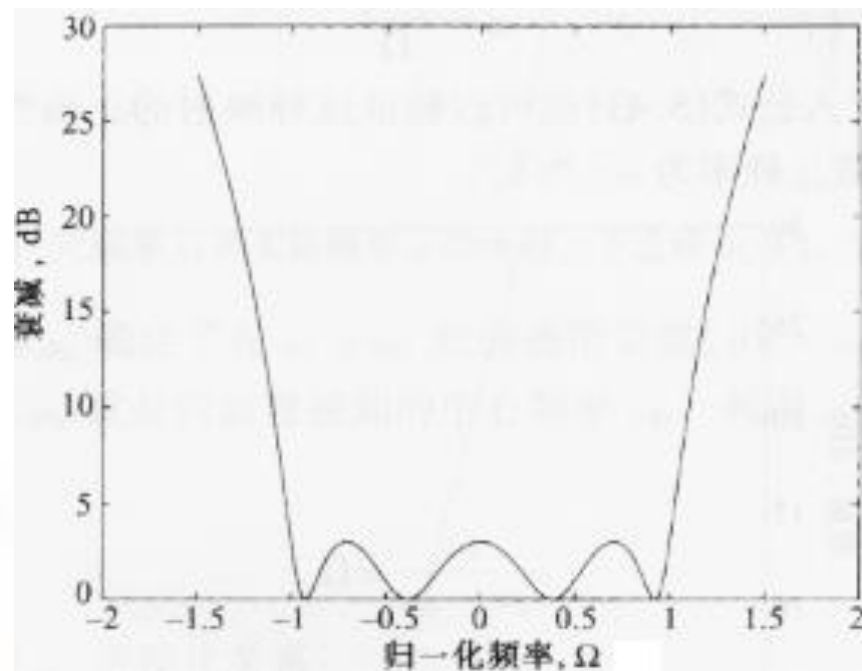

5.2.3 标准低通滤波器的反归一化

对高通滤波器： $\omega = -\omega_c/\Omega$

归一化电抗：

$$jX_L = j\Omega L = -j\frac{\omega_c}{\omega}L = \frac{1}{j\omega\tilde{C}}$$

$$jX_C = \frac{1}{j\Omega C} = -\frac{\omega}{j\omega_c C} = j\omega\tilde{L}$$

实际电容： $\tilde{C} = \frac{1}{\omega_c L}$

实际电感： $\tilde{L} = \frac{1}{\omega_c C}$

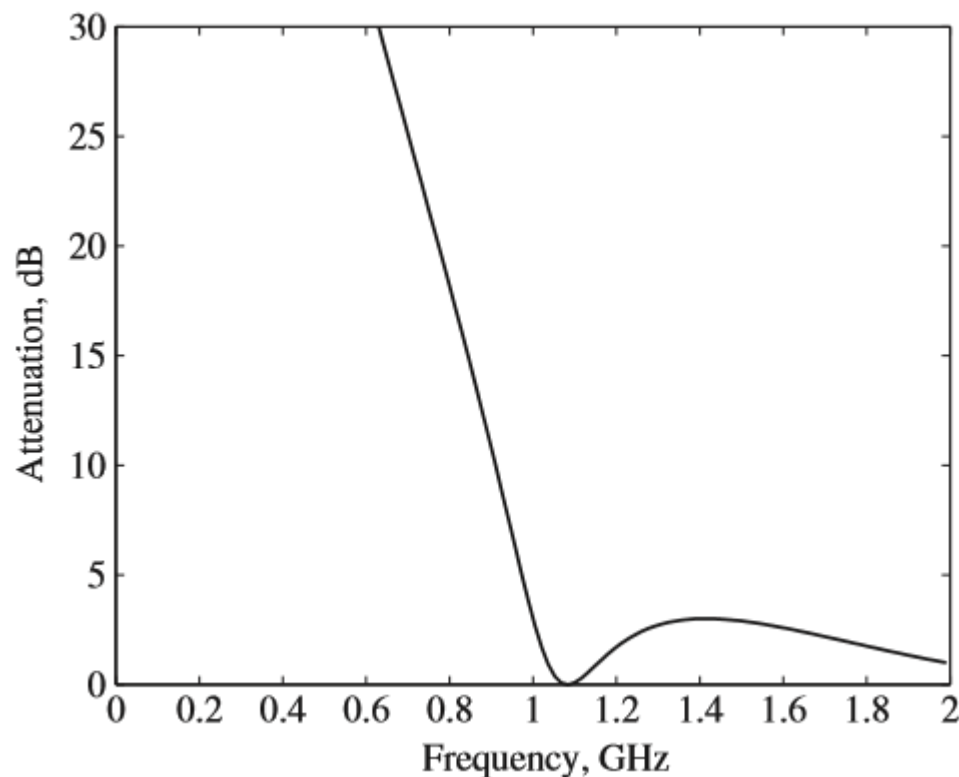

5.2.3 标准低通滤波器的反归一化

对带通滤波器，实现比例变换和平移的函数关系：

$$\Omega = \frac{1}{\omega_U / \omega_c - \omega_L / \omega_c} \left(\frac{\omega}{\omega_c} - \frac{1}{\omega / \omega_c} \right) = \frac{\omega_c}{\omega_U - \omega_L} \left(\frac{\omega}{\omega_c} - \frac{\omega_c}{\omega} \right)$$

其中上边频和下边频成反比关系： $\frac{\omega_U}{\omega_0} = \frac{\omega_0}{\omega_L}$

则频率变换关系： $0 \leq \Omega \leq 1 \rightarrow \omega_0 \leq \omega \leq \omega_U$
 $-1 \leq \Omega \leq 0 \rightarrow \omega_L \leq \omega \leq -\omega_0$

串联参数的变换：

$$jX_L = j\Omega L = j \frac{\omega_0}{\omega_U - \omega_L} \left(\frac{\omega}{\omega_0} - \frac{\omega_0}{\omega} \right) L = j\omega \tilde{L} + \frac{1}{j\omega \tilde{C}}$$

故串联电感： $\tilde{L} = \frac{L}{\omega_U - \omega_L}$

串联电容： $\tilde{C} = \frac{\omega_U - \omega_L}{\omega_0^2 L}$

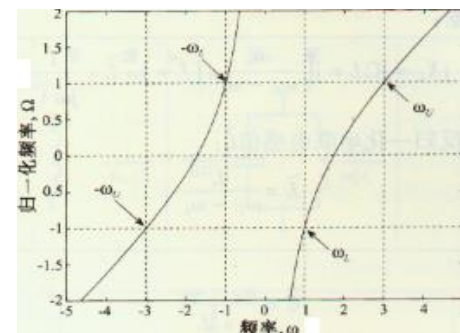

$$\omega_0 = \omega_c = \sqrt{\omega_U \omega_L}$$

$$\omega = \omega_c, \quad \Omega = 0$$

$$\omega = \omega_L, \quad \Omega = -1$$

$$\omega = \omega_U, \quad \Omega = 1$$

5.2.3 标准低通滤波器的反归一化

并联参数的变换：

$$jB_C = j\Omega C = j \frac{\omega_0}{\omega_U - \omega_L} \left(\frac{\omega}{\omega_{0c}} - \frac{\omega_0}{\omega} \right) C = j\omega\tilde{C} + \frac{1}{j\omega\tilde{L}}$$

$$\text{并联电感: } \tilde{L} = \frac{\omega_U - \omega_L}{\omega_0^2 C} \quad \text{并联电容: } \tilde{C} = \frac{C}{\omega_U - \omega_L}$$











对于带阻滤波器，通过5.46式的倒数变换可得：

$$\text{串联电感: } \tilde{L} = (\omega_U - \omega_L)L / \omega_0^2 \quad \text{串联电容: } \tilde{C} = 1 / (\omega_U - \omega_L)L$$

$$\text{并联电感: } \tilde{L} = 1 / (\omega_U - \omega_L)C \quad \text{并联电容: } \tilde{C} = (\omega_U - \omega_L)C / \omega_0^2$$

5.2.3 标准低通滤波器的反归一化

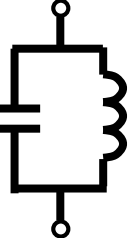
归一化低通到实际低通、高通、带通和带阻滤波器的变换

	低通原型	实际低通	实际高通	实际带通	实际带阻
串联元件	 $L = g_k$	 $\frac{L}{\omega_c}$	 $\frac{1}{\omega_c L}$	 $\frac{L}{BW} \quad \frac{BW}{\omega_0^2 L}$	 $(BW)L / \omega_0^2$ $1 / (BW)L$
并联元件	 $C = g_k$	 $\frac{C}{\omega_c}$	 $\frac{1}{\omega_c C}$	 $\frac{C}{BW} \quad \frac{BW}{\omega_0^2 C}$	 $\frac{1}{(BW)C}$ $\frac{(BW)C}{\omega_0^2}$

2. 阻抗变换：将标准信号源阻抗 g_0 和负载阻抗 g_{N+1} 变换为实际的源阻抗和负载阻抗。

$$\tilde{R}_G = \tilde{R}_L = R_G = R_L, \quad \tilde{L} = LR_G, \quad \tilde{C} = C / R_G$$

原型低通的源阻抗和负载阻抗除偶阶切比雪夫滤波器外均为1，若实际阻抗为 R_G ，则实际滤波器的元件参数如上

5.2.3 标准低通滤波器的反归一化

例5.3 设计一个 $N = 3$ ，带内波纹为3dB的切比雪夫滤波器。中心频率2.4GHz，带宽20%，输入、输出阻抗为50Ω。

解：查表5.4(a)可得：

$$g_0 = g_4 = 1, \quad g_1 = g_3 = 3.3487, \quad g_2 = 0.7117。$$

实际阻抗： $\tilde{R}_G = \tilde{R}_L = R_G = R_L = 50\Omega$

$$\omega_U = 1.1 \times 2\pi \times 2.4 \times 10^9 = 16.59 \times 10^9$$

$$\omega_L = 0.9 \times 2\pi \times 2.4 \times 10^9 = 13.57 \times 10^9$$

$$\text{则：} \tilde{L}_1 = \tilde{L}_3 = R_G L_1 / (\omega_U - \omega_L) = 55.5\text{nH}$$

$$\tilde{C}_1 = \tilde{C}_3 = (\omega_U - \omega_L) / \omega_0^2 R_G L_1 = 80\text{fF}$$

$$\tilde{L}_2 = R_G (\omega_U - \omega_L) / \omega_0^2 C_2 = 0.94\text{nH}$$

$$\tilde{C}_2 = C_2 / R_G (\omega_U - \omega_L) = 4.7\text{pF}$$

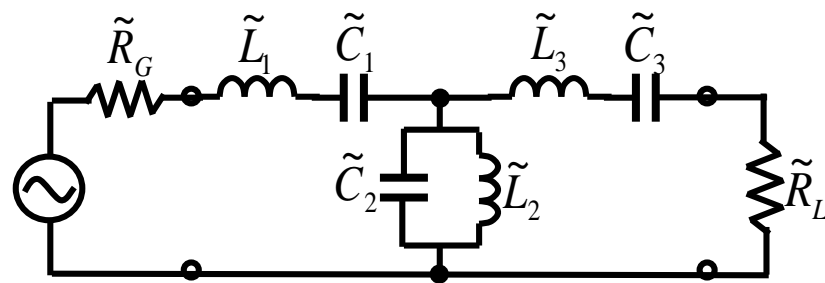
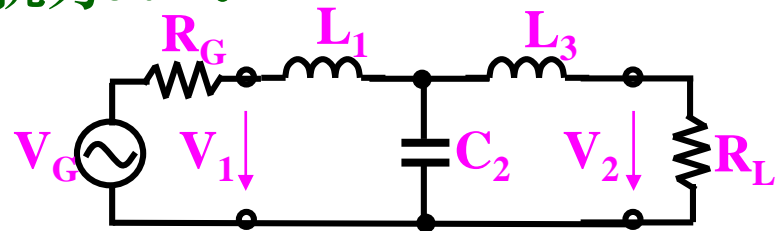

滤波器设计方法总结

1. 原型：设计低通原型滤波器

① 计算归一化频率：

低通滤波器： $\omega = \Omega \omega_c$

高通滤波器： $\omega = -\omega_c / \Omega$

带通滤波器： $\Omega = \frac{\omega_c}{\omega_U - \omega_L} \left(\frac{\omega}{\omega_c} - \frac{\omega_c}{\omega} \right)$



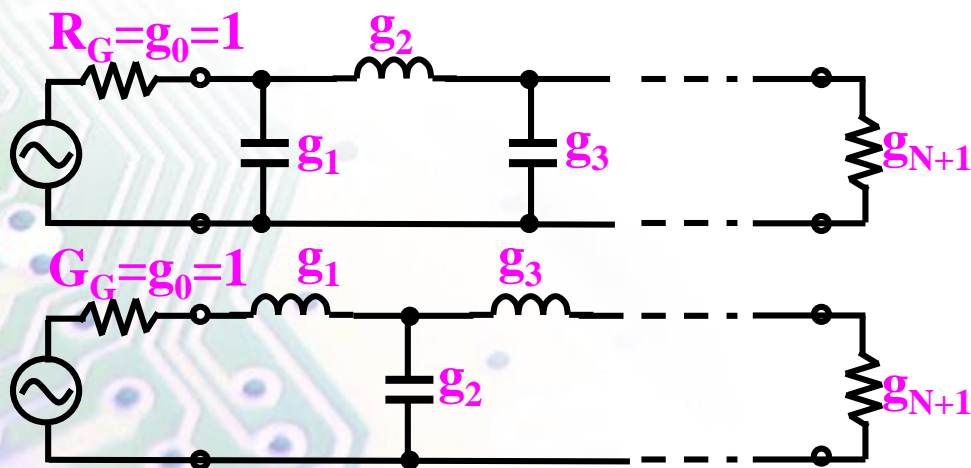



② 根据低通原型确定滤波器阶数，查表得到归一化参数：

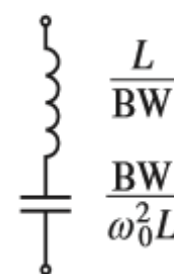
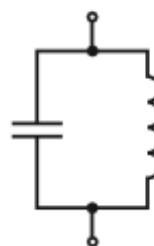

滤波器设计方法总结

2. 变换：原型变换为实际滤波器；阻抗变换为实际阻抗。

① 归一化低通到实际低通、高通、带通和带阻滤波器的变换

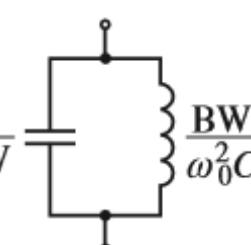
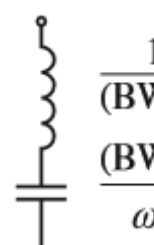
Low-pass prototype	Low-pass	High-pass	Bandpass	Bandstop
 $L = g_k$	 $\frac{L}{\omega_c}$	 $\frac{1}{\omega_c L}$	 $\frac{L}{BW}$ $\frac{BW}{\omega_0^2 L}$	 $\frac{1}{(BW)L}$ $\frac{(BW)L}{\omega_0^2}$
 $C = g_k$	 $\frac{C}{\omega_c}$	 $\frac{1}{\omega_c C}$	 $\frac{C}{BW}$ $\frac{BW}{\omega_0^2 C}$	 $\frac{1}{(BW)C}$ $\frac{(BW)C}{\omega_0^2}$

② 阻抗变换 $\tilde{R}_G = \tilde{R}_L = R_G = R_L$, $\tilde{L} = LR_G$, $\tilde{C} = C / R_G$

滤波器设计举例

- 请根据以下要求设计一个高通滤波器：通带起始频率为60MHz，在30MHz时衰减达到40dB，源阻抗和负载阻抗均为300欧。通带波纹为0.5dB。

解： **1. 原型：设计低通原型滤波器**

① 计算归一化频率：

对高通滤波器： $\omega = -\omega_c / \Omega$

本例中： $\omega_c = \pm 60\text{MHz}$ ，则 $\omega = 30\text{MHz}$ 时，

对应的 $\Omega = \omega_c / \omega = 2$

② 根据允许0.5dB的通带内波纹、 $\Omega=2$ 时衰减达到40dB这两个条件，查找图5.22 滤波器的响应曲线图，可得 $n=5$

滤波器设计举例

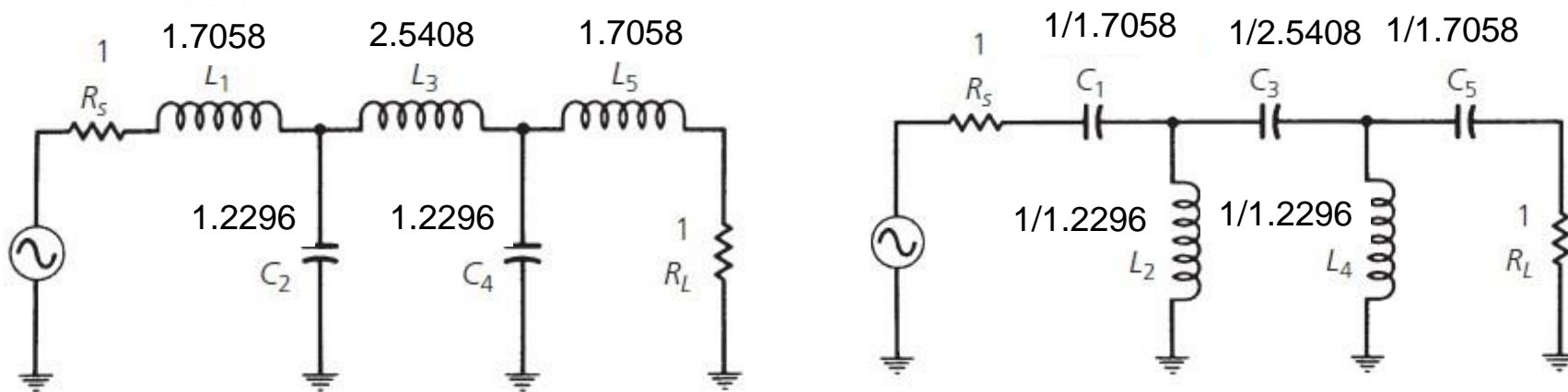

2. 变换：原型变换为实际滤波器；阻抗变换为实际阻抗。

$$C_1 = \frac{1/1.7058}{2\pi(60 \times 10^6)(300)} = 5.18\text{pF}$$

$$C_3 = 3.48\text{pF}$$

$$L_2 = \frac{1/1.2296}{2\pi(60 \times 10^6)} 300 = 647\text{nH}$$

$$C_5 = 5.18\text{pF}$$

$$L_4 = 647\text{nH}$$

滤波器设计举例

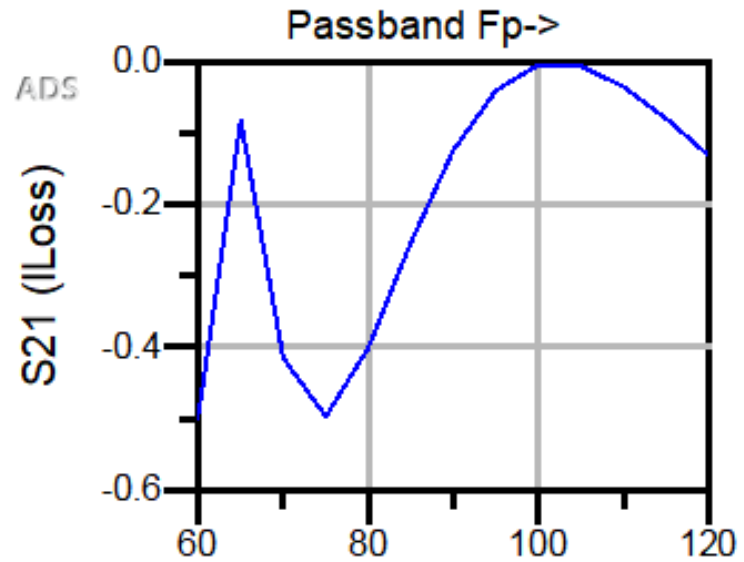
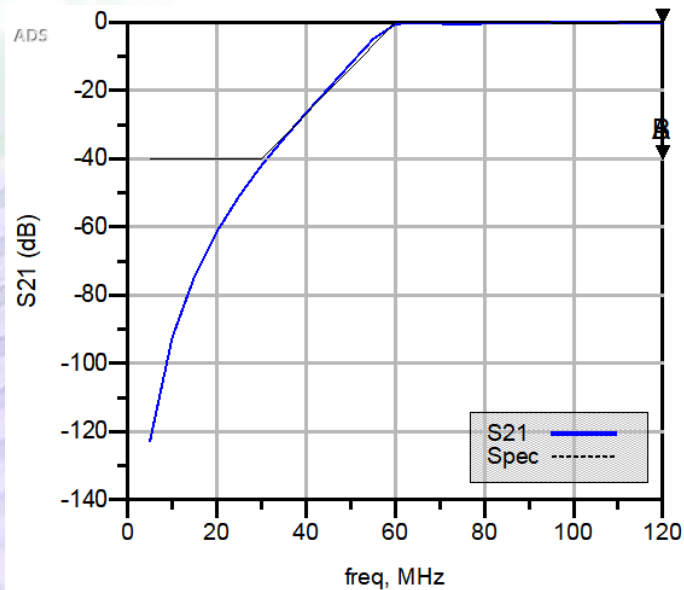
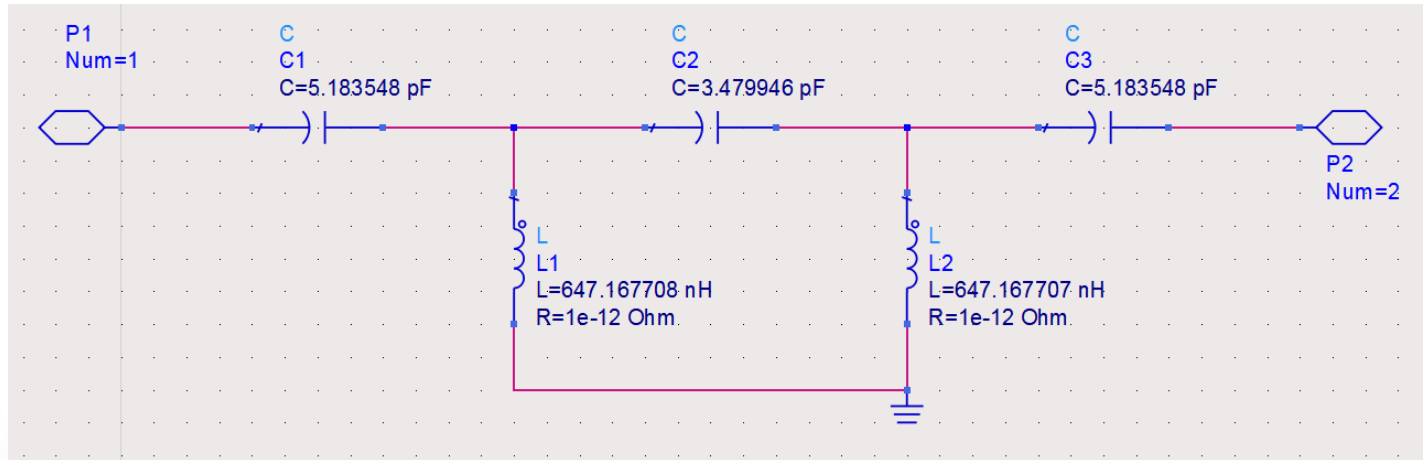

5.3 滤波器的实现 - 理查兹变换

- 工作频率超过500MHz的滤波器用分立元件难以实现，
- 理查兹提出将一段开路或短路传输线等效于分布的电感或电容。

$$\text{短路 } Z_{in}(d) = jZ_0 \tan(\beta d) = jZ_0 \tan \theta \quad \text{开路 } Z_{in}(d) = -jZ_0 / \tan(\beta d) = -jZ_0 / \tan \theta$$

若传输线长度为 $\lambda_0/8$ ， $f_0 = v_p/\lambda_0$ ，则电长度：

$$\theta = \beta \frac{\lambda_0}{8} = \frac{2\pi f}{v_p} \frac{v_p}{8f_0} = \frac{\pi f}{4f_0} = \frac{\pi}{4} \Omega$$

故传输线电感和集总参数之间的关系为： $jX_L = j\omega L = jZ_0 \tan\left(\frac{\pi}{4}\Omega\right) = SZ_0$

电容集总参数可用一段开路传输线实现： $jB_C = j\omega C = jY_0 \tan\left(\frac{\pi}{4}\Omega\right) = SY_0$

其中 $S = j \tan(\Omega\pi/4)$ 就是理查兹变换(在归一化频率处 $S=j1$)。

因此理查兹变换可用 $Z_0=L$ 的一段短路传输线替代集总参数电感，也可用 $Z_0=1/C$ 的一段开路传输线替代集总参数电容。

5.3 滤波器的实现

5.3.1 单位元件

在把集总参数元件变成传输线段时，需要分解传输线元件，即插入**单位元件**以便得到可以实现的电路结构。单位元件可视为两端口网络，其电长度 $\theta = \frac{\pi}{4}(f/f_0)$ ，特性阻抗为 Z_{UE} 。

传输线参量：

$$[UE] = \begin{bmatrix} A_{UE} & B_{UE} \\ C_{UE} & D_{UE} \end{bmatrix} = \begin{bmatrix} \cos \theta & jZ_{UE} \sin \theta \\ \frac{j \sin \theta}{Z_{UE}} & \cos \theta \end{bmatrix} = \frac{1}{\sqrt{1-S^2}} \begin{bmatrix} 1 & Z_{UE}S \\ \frac{S}{Z_{UE}} & 1 \end{bmatrix}$$

5.3 滤波器的实现

5.3.2 Kuroda (黑田) 规则

除引入单位元件外，同样重要的是将工程上难以实现的滤波器设计转换成容易实现的形式。例如实现等效的串联电感时，采用短路传输线段比采用并联开路传输线段更困难。

为了方便各种传输线结构的相互变换，提出了四个规则。

原始电路	Kuroda 规则	原始电路	Kuroda 规则
<p>原始电路: 串联电容 $Y_C = S/Z_2$ 后接单位元件 Z_1</p>	<p>Kuroda 规则: 单位元件 Z_2/N 后接串联电感 $Z_L = SZ_1/N$</p>	<p>原始电路: 串联电容 $Y_C = S/Z_2$ 后接单位元件 Z_1</p>	<p>Kuroda 规则: 单位元件 NZ_1 后接并联电感 $Z_L = S/NZ_2$ (N : 1)</p>
<p>原始电路: 串联电感 $Z_L = Z_1S$ 后接单位元件 Z_2</p>	<p>Kuroda 规则: 单位元件 NZ_1 后接并联电容 $Y_C = S/NZ_2$</p>	<p>原始电路: 串联电感 $Z_L = Z_1S$ 后接单位元件 Z_2</p>	<p>Kuroda 规则: 单位元件 Z_2/N 后接并联电感 $Z_L = SZ_1/N$ (1 : N)</p>

$$N = 1 + Z_2 / Z_1$$

5.3 滤波器的实现

例5.4 证明第一个Kuroda规则。

解：原始参量

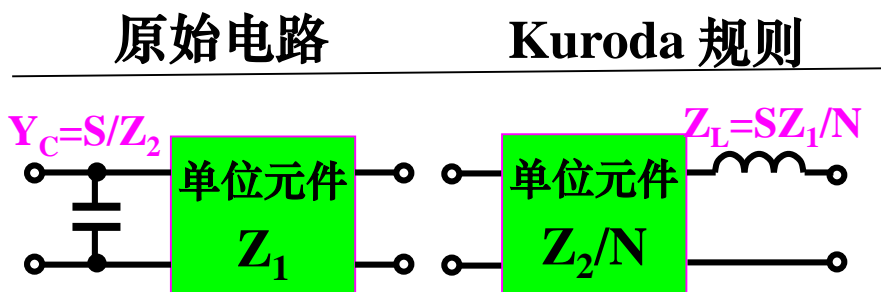

$$\begin{bmatrix} A & B \\ C & D \end{bmatrix} = \begin{bmatrix} 1 & 0 \\ \frac{S}{Z_2} & 1 \end{bmatrix} \frac{1}{\sqrt{1-S^2}} \begin{bmatrix} 1 & SZ_1 \\ \frac{S}{Z_1} & 1 \end{bmatrix} = \frac{1}{\sqrt{1-S^2}} \begin{bmatrix} 1 & SZ_1 \\ \frac{S}{Z_1} + \frac{S}{Z_2} & 1 + \frac{S^2 Z_1}{Z_2} \end{bmatrix}$$

变换参量

$$\begin{bmatrix} A & B \\ C & D \end{bmatrix} = \frac{1}{\sqrt{1-S^2}} \begin{bmatrix} 1 & \frac{SZ_2}{N} \\ \frac{SN}{Z_2} & 1 \end{bmatrix} \begin{bmatrix} 1 & \frac{SZ_1}{N} \\ 0 & 1 \end{bmatrix} = \frac{1}{\sqrt{1-S^2}} \begin{bmatrix} 1 & \frac{S(Z_1 + Z_2)}{N} \\ \frac{SN}{Z_2} & 1 + \frac{S^2 Z_1}{Z_2} \end{bmatrix}$$

将 $N=1+Z_2/Z_1$ 代入变换参量中即等于原始参量，在截止频率处： $S=j\tan 45=j$

5.3 滤波器的实现

5.3.3 微带线滤波器的设计实例

任务I: 设计一个输入输出阻抗为 50Ω 的低通， $f_c = 3\text{GHz}$ ，波纹 0.5dB ， $2f_c$ 时损耗不小于 40dB ， v_p 为光速的 60% 。

步骤 1: 根据设计要求选择归一化参数。

由P152图5.22和表5.4(b)，

$N=5$ ， $g_1=g_5=1.7058$ ， $g_2=g_4=1.2296$ ， $g_3=2.5408$ ， $g_6=1$ 。

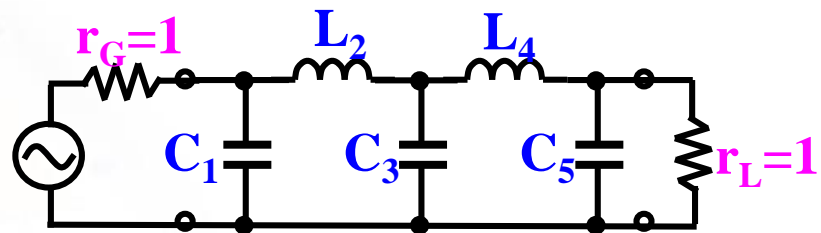

5.3 滤波器的实现

步骤 2: 用 $\lambda_0/8$ 传输线替换电感和电容。

由5.64式和5.65式, $Y_1=Y_5=g_5$, $Y_3=g_3$, $Z_2=Z_4=g_4$ 。

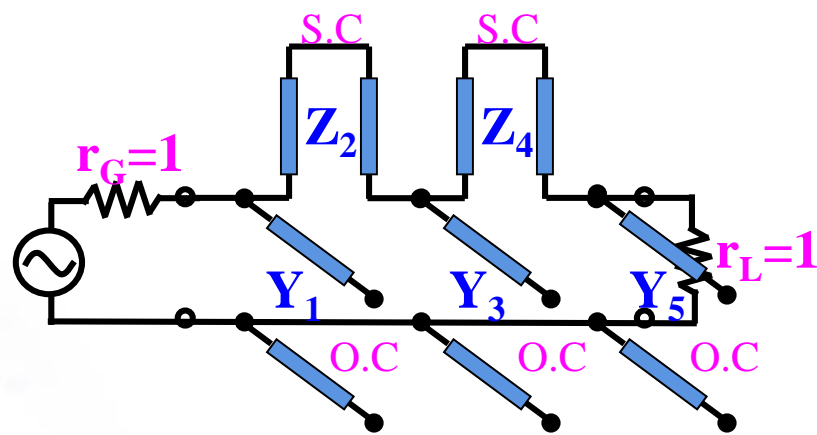
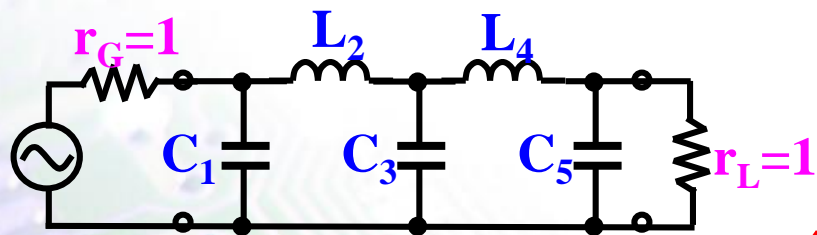

5.3 滤波器的实现

步骤 3: 根据 Kuroda 规则将串联短线变换为并联短线。

首先在滤波器的输入
 输出口引入两个单位
 元件。其中 $Z_1=0.5862$
 $Z_2=1.2296$ $Z_3=0.3936$
 $Z_4=1.2296$ $Z_5=0.5862$

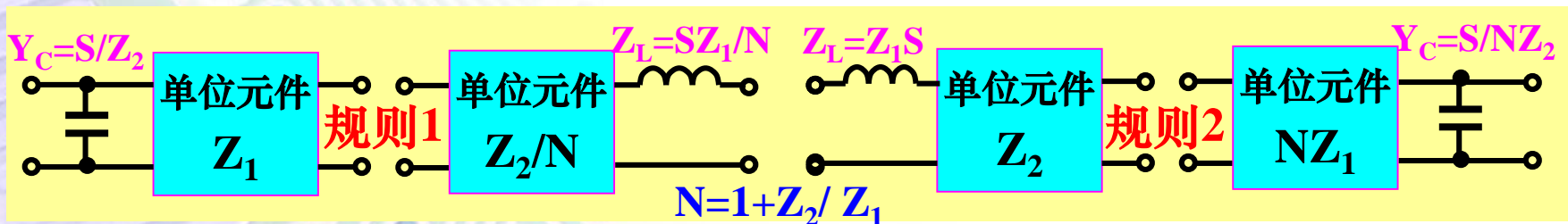
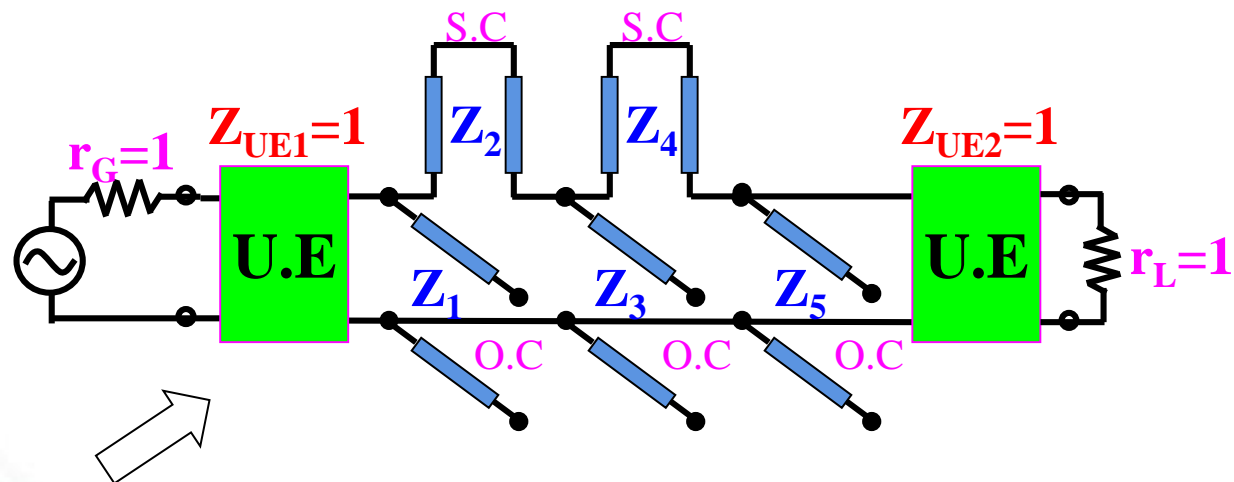

5.3 滤波器的实现

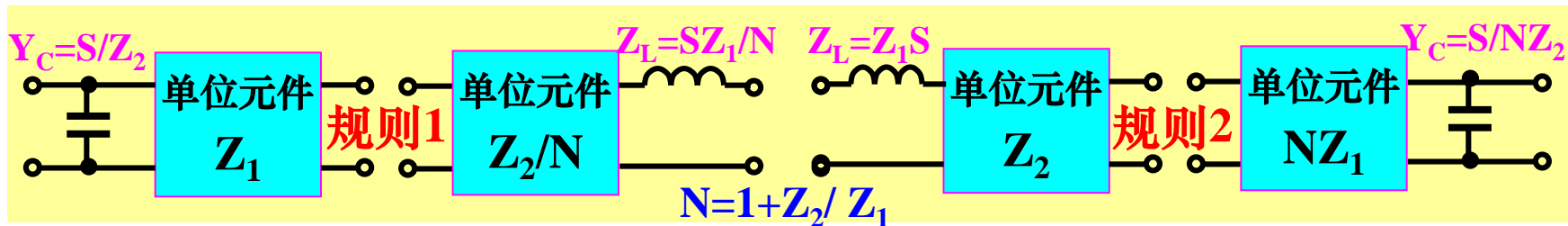

输入端用规则2、输出端用规则1将并联开路线变换为串联短路线。

由规则2（输出端）：

$$NZ_1 = 1$$

$$NZ_2 = 1/Y_C = 0.5862$$

$$N = 1 + Z_2/Z_1 = 1.5862$$

$$Z_L = Z_1 = 1/N = 0.6304$$

$$Z_2 = 1/(NY_C) = 0.3696$$

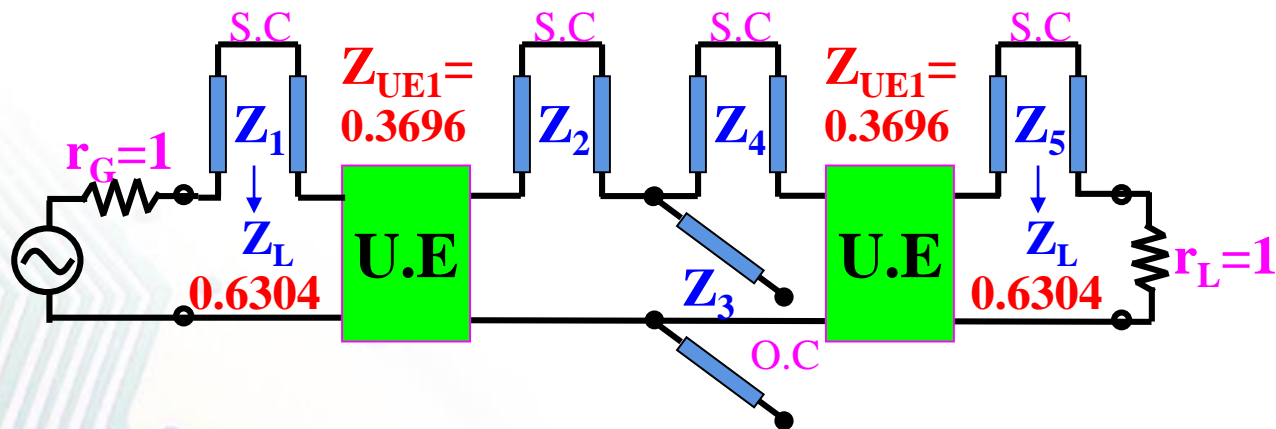

5.3 滤波器的实现

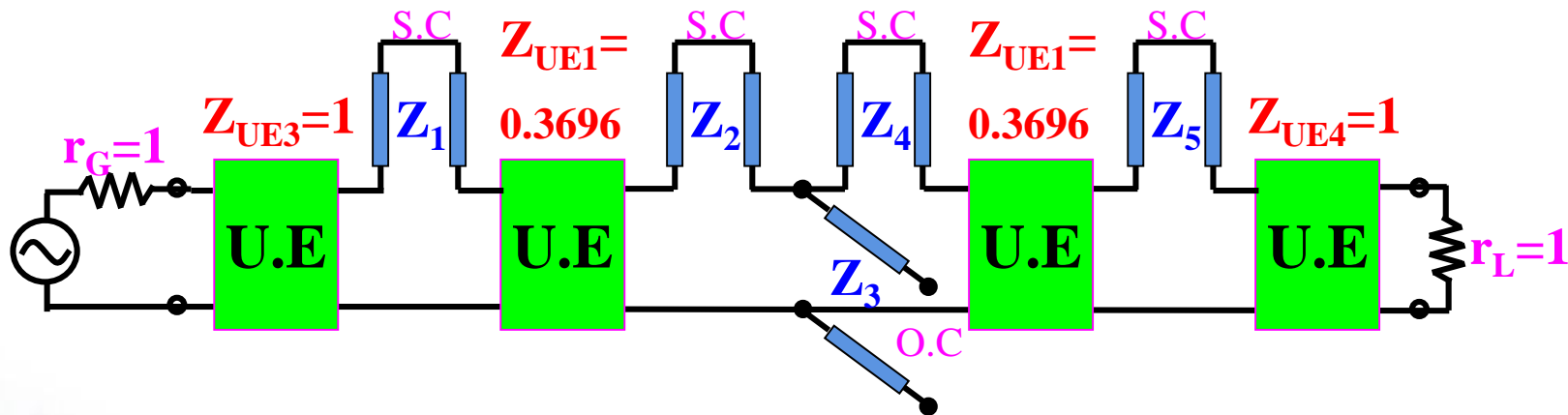

用规则1对 Z_{UE3} 变换: $Z_2/N=1, Z_1/N=0.6304, N=1+Z_2/Z_1=2.5863,$
 $Y_C=1/Z_2=0.3867, Z_1=0.6304N=1.6304;$

用规则1对 Z_{UE1} 变换: $Z_2/N=0.3696, Z_1/N=1.2296, N=1+Z_2/Z_1=1.3006,$
 $Y_C=1/Z_2=1/0.3696N=2.0803, Z_1=1.2296N=1.5992。$

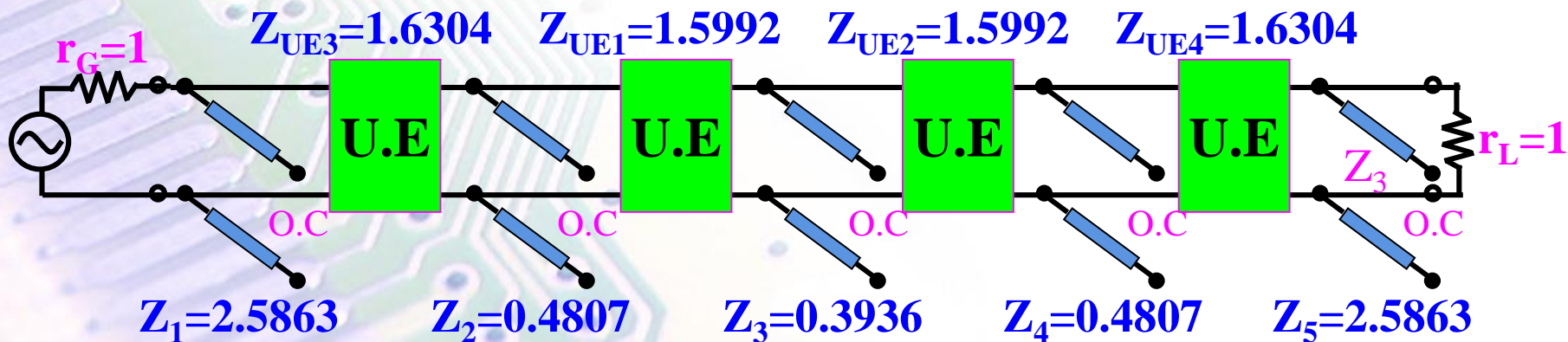

5.3 滤波器的实现

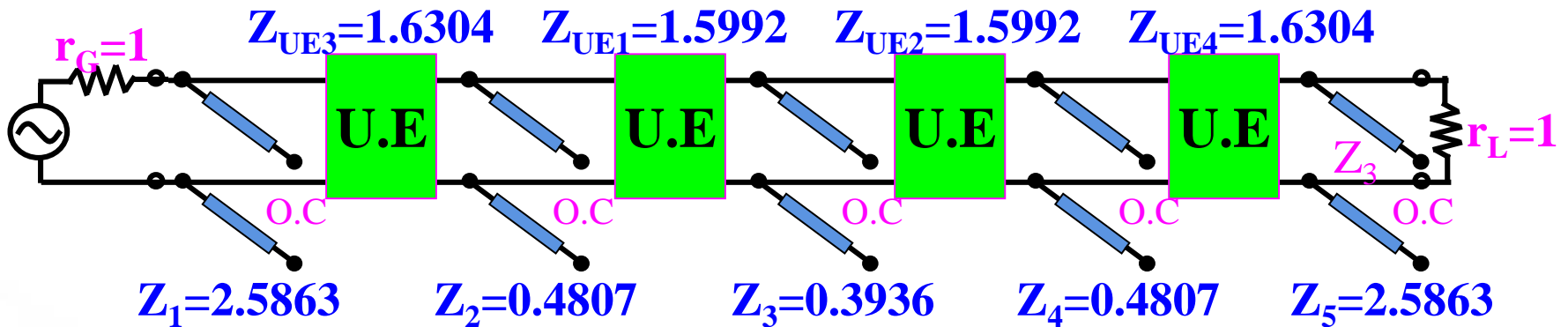

步骤 4: 反归一化将单位元件的输入、输出阻抗变成 50Ω 的比例, 并计算微带线的长度和宽度 (P41表2.1)。

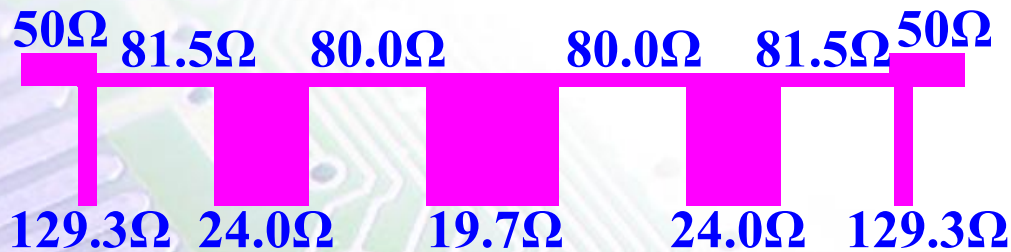

$$l = \frac{\lambda_0}{8} = \frac{v_p}{8f_0} = \frac{0.6c}{8f_0}$$

$$= \frac{1.8 \times 10^8}{24 \times 10^9} = 0.0075\text{m} = 7.5\text{mm}$$

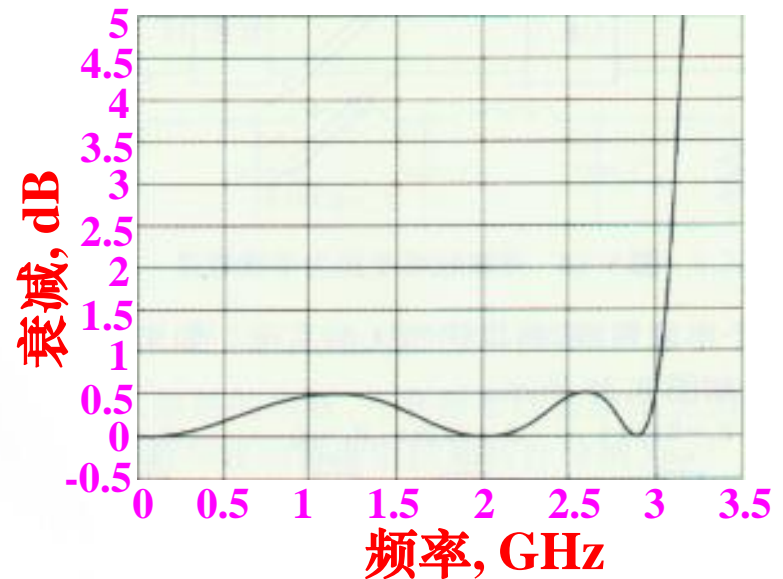

滤波器大作业

设计一款阶数为5的带通或带阻滤波器。

1. 计算出其低通原型的LC元件值；
2. 通过频率变换，计算带通或带阻滤波器对应的LC元件值；
3. 利用Matlab或ADS软件，给出该滤波器的频率响应特性（幅度和相位）；
4. （选做）采用50欧姆接口的微带线实现该滤波器，根据教材例子，给出滤波器的拓扑结构，并计算每段传输线的阻抗；
5. （选做）在HFSS，ADS或CST软件中对你设计的微带滤波器建模，并仿真其频率特性。

指标要求：

1. 学号为**单数**的做**带通**滤波器，学号为**双数**的做**带阻**滤波器；
2. 滤波器的中心频率统一为2.4 GHz，带内波纹0.5dB；
3. 滤波器的3dB**带宽为学号最后一位**，如果为0则带宽为10%。例如，某学生学号最后一位为5，则设计3dB带宽为 $2.4 * 0.05 = 0.12$ GHz的带通滤波器。

提交形式：文件名为“学号_姓名.docx/doc”发至 yzhang627@xjtu.edu.cn

截止日期：2020-11-20

例、设计最平坦响应低通滤波器，通带内波纹系数小于2，截至频率4GHz，8GHz处插入损耗必须大于15dB，阻抗50Ω

使用ADS滤波器设计向导工具设计

➤ 建立新的设计，选择【Filter DG – All】中的“DT”

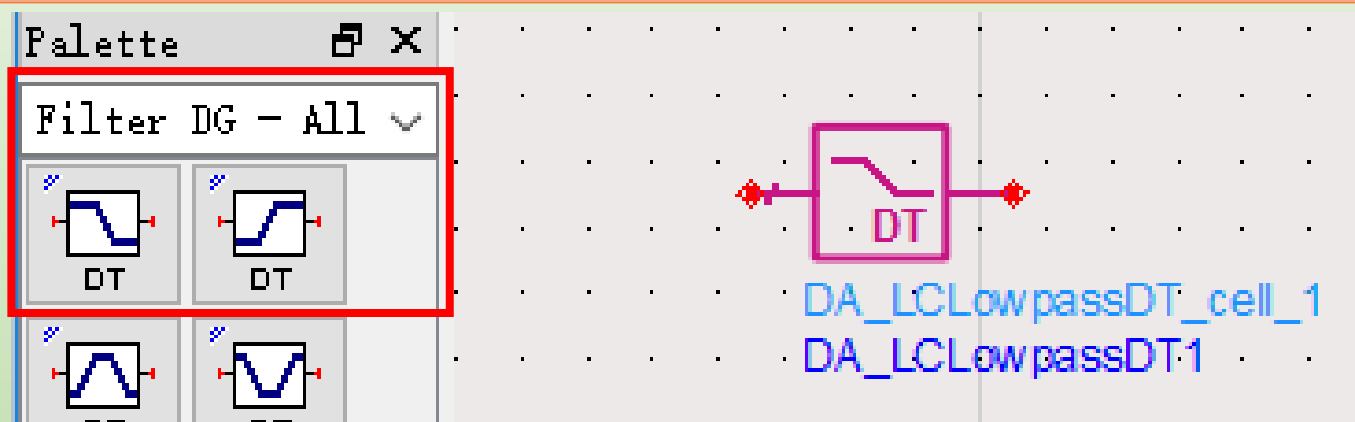

➤ 菜单命令【 Design Guide】→【Filter】，弹出对话框，选择如下图所示，然后“OK”

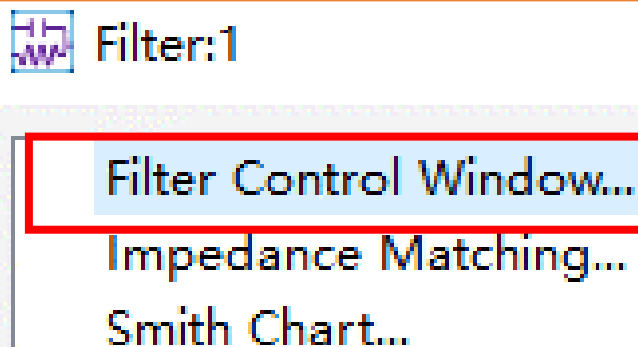

Current Schematic: cell_2 [filter_lib:cell_2:schematic]: 5

SmartComponent: DA_LCLowpassDT1

Current Design: schematic

SmartComponent Capability: Design, Simulate, Yield, Display

Overview | **Filter Assistant** | Simulation Assistant | Yield Assistant | Display Assistant

Impedances: Source 50, Load 50

First Element: Series

Order (N): 3

Design Information: Order: 3, Minimum Insertion Loss: 0.0000

Response Type: Maximally Flat

Ap (dB): 2

As (dB): 15

2 dB/

Realizations: View All, Max #: 1

Fp: 4, Fs: 8, Units: GHz

Design | Redraw | Help

➤ 单击“Design”返回原理图

➤ 在原理图中，选中DT1，单击工具栏图标  得到电路

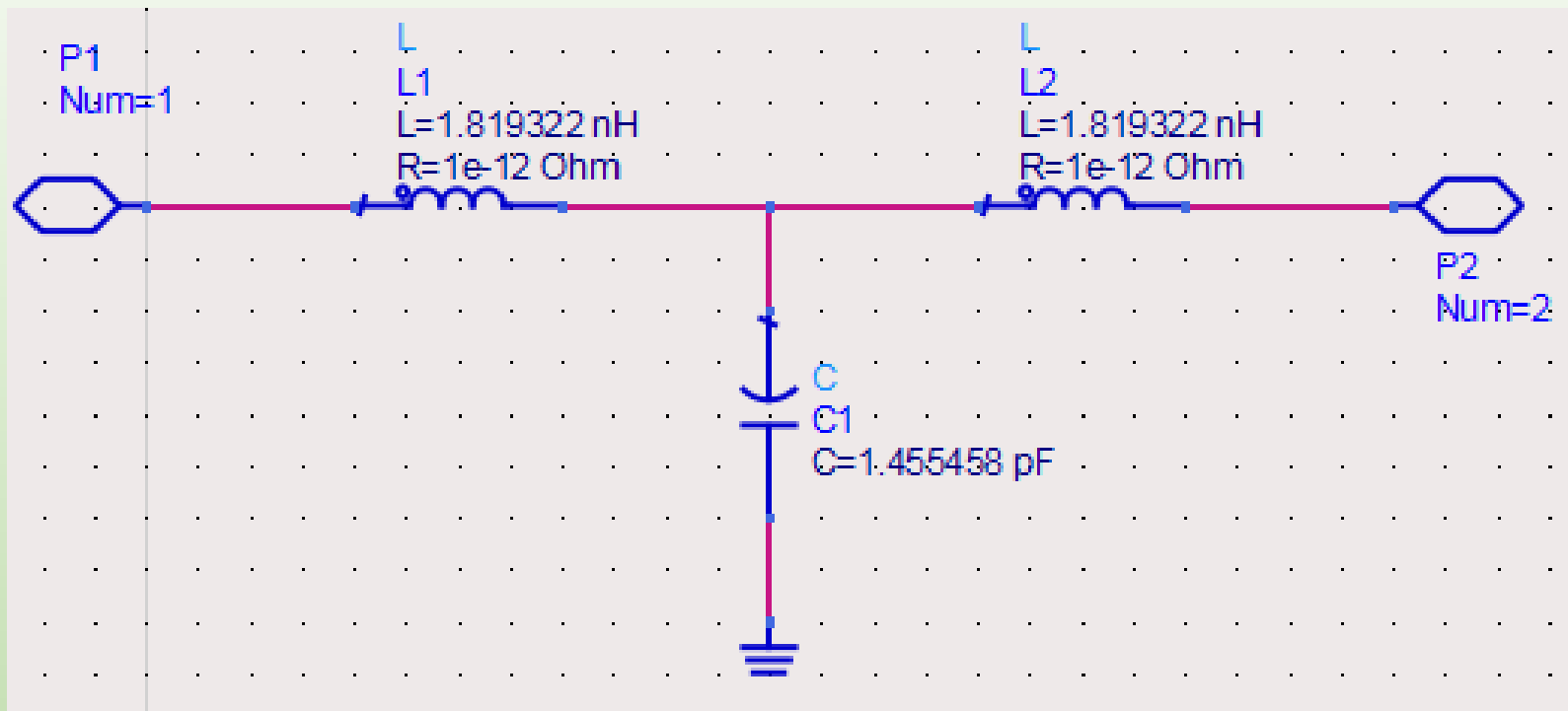

➤ 单击工具栏 

➤ 双击  打开参数设置，选中要显示的参数，如下图

Display parameter on schematic

Component Options...

Apply

OK

完成电路，并仿真

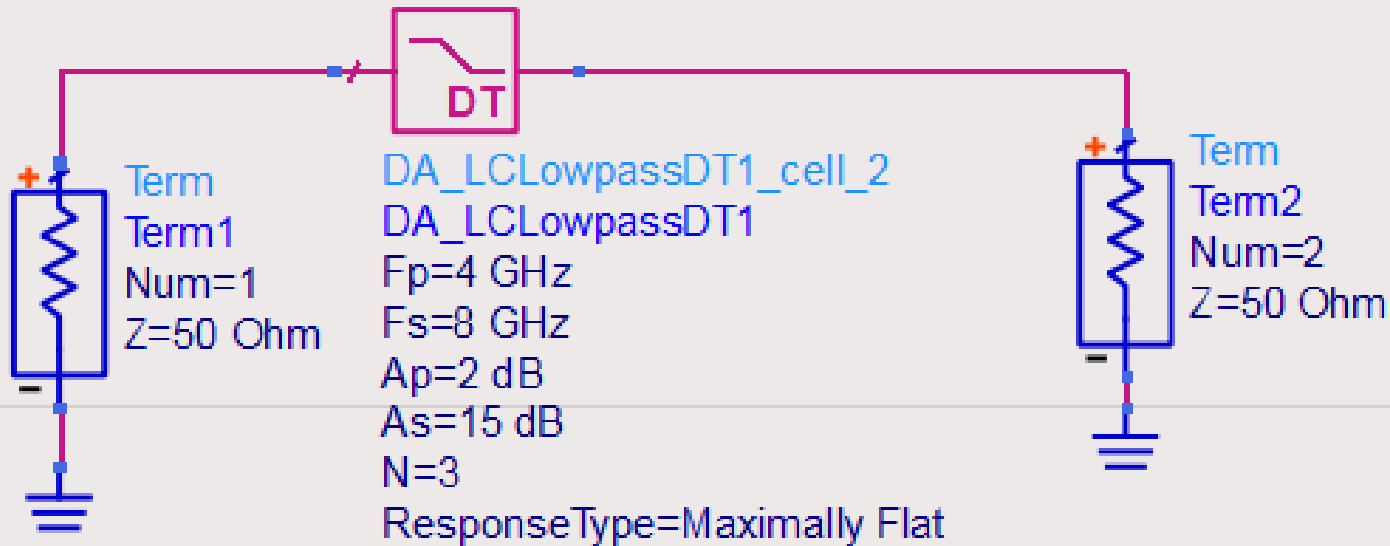

S-PARAMETERS

S_Param
SP1
Start=0 GHz
Stop=10 GHz
Step=10 MHz

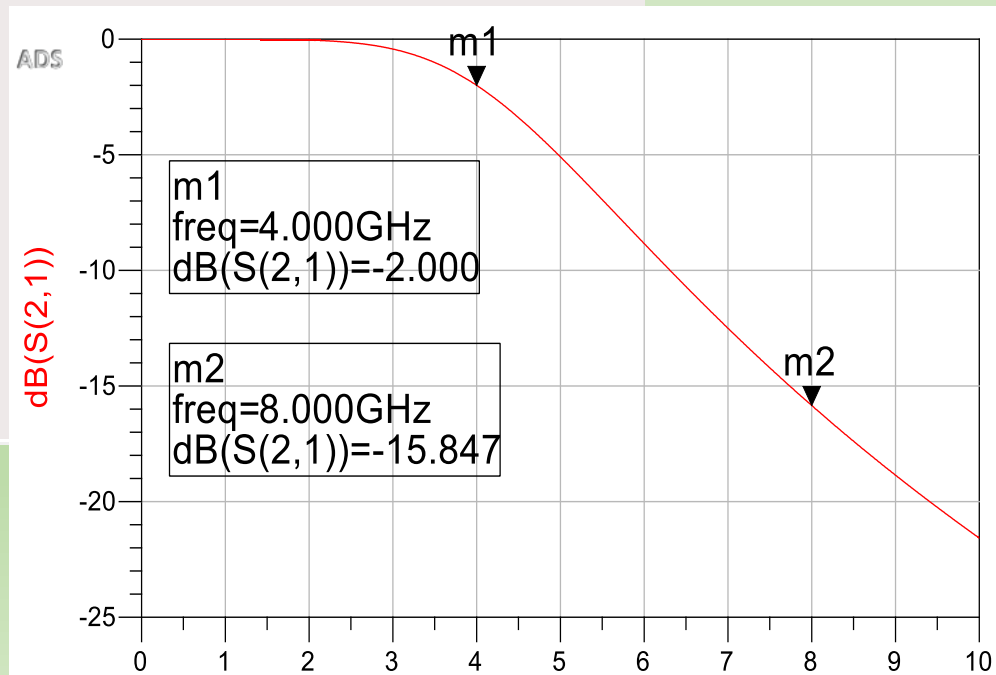

- 由于电路工作频率高，不宜采用集总元件，需转换为分布参数元件。

➤ 转换分为三步：

1. 根据Richards变换，电容、电感转换为开路、短路短截线。
2. 根据Kuroda等效，串联短截线转换为并联短截线。
3. 选择微带线参数（厚度、介电常数及介质损耗等），由计算的特性阻抗确定各部分微带线尺寸，进行电路仿真

。

➤ 打开Filter设计向导，单击工具栏  ，打开滤波器转换助手对话框

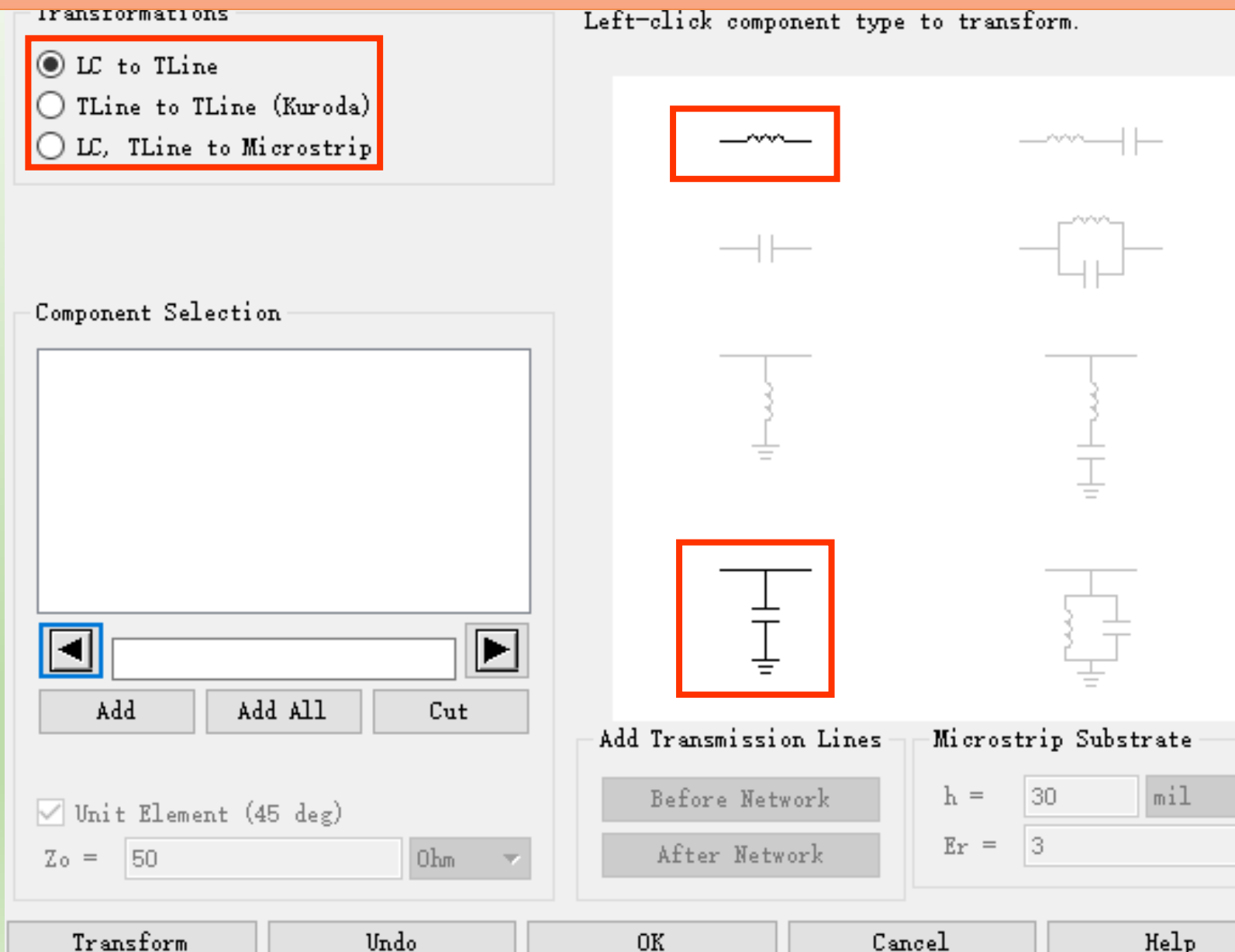

➤ 选中电感 → 【Add All】：电感L1和L2同时选中

➤ 单击串联短路短截线 → 【Transform】 → 单击 

Transformations

- LC to TLine
- TLine to TLine (Kuroda)
- LC, TLine to Microstrip

Component Selection

L1
L2

L1

Add

Add All

Cut

Unit Element (45 deg)

Zo = 50

Ohm

Left-click desired transformed topology.

Left-click return arrow to return to main transform

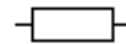
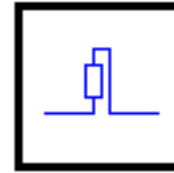
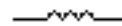

Add Transmission Lines

Before Network

After Network

Microstrip Substrate

h = 30 mil

Er = 3

Transform

Undo

OK

Cancel

Help

➤ 选中**电容**→【Add】

➤ 单击并联开路短截线→【Transform】→单击

Transformations

- LC to TLine
- TLine to TLine (Kuroda)
- LC, TLine to Microstrip

Component Selection

C1

C1

Add

Add All

Cut

Unit Element (45 deg)

Zo = 50

Ohm

Transform

Undo

OK

Cancel

Help

Left-click desired transformed topology.

Left-click return arrow to return to main transform

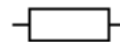
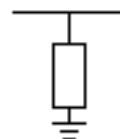
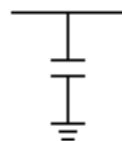
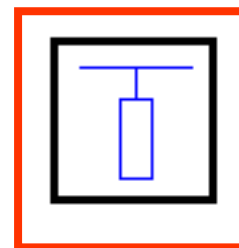

Add Transmission Lines

Before Network

After Network

Microstrip Substrate

h = 30

Er = 3

L、C转换为微带短截线设计结果

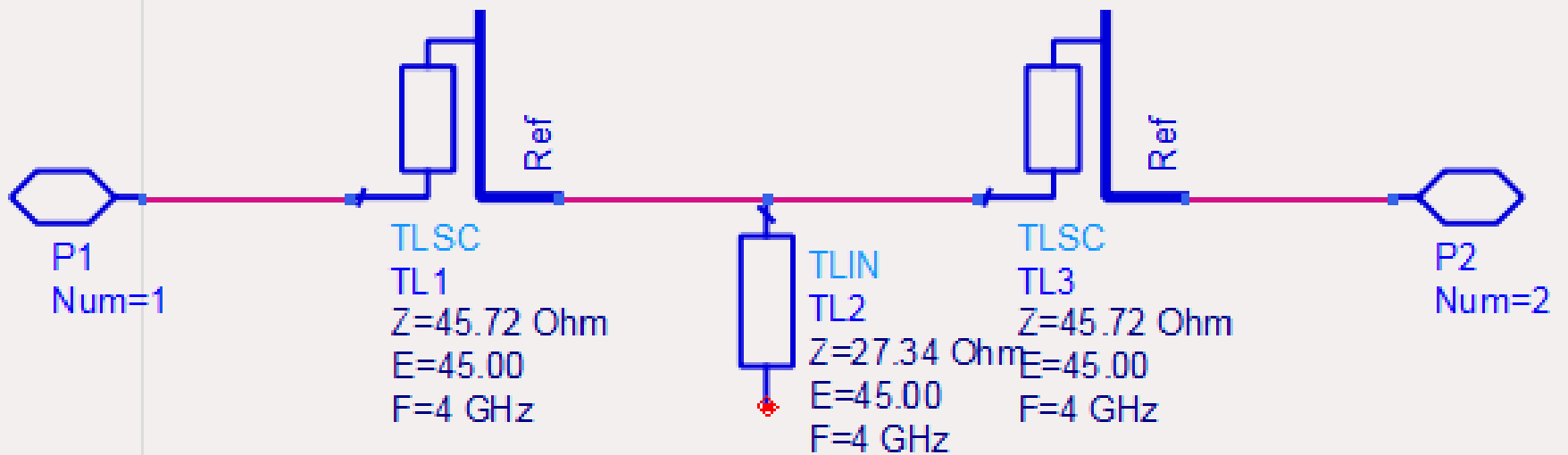

➤ 选中“TLine to TLine (Kuroda)” (串转并)

➤ 【Before Network】 → 【After Network】

Left-click return arrow to return to main transform page.

- LC to TLine
- TLine to TLine (Kuroda)
- LC, TLine to Microstrip

Component Selection



Add Add All Cut

Unit Element (45 deg)

Zo = 50 Ohm

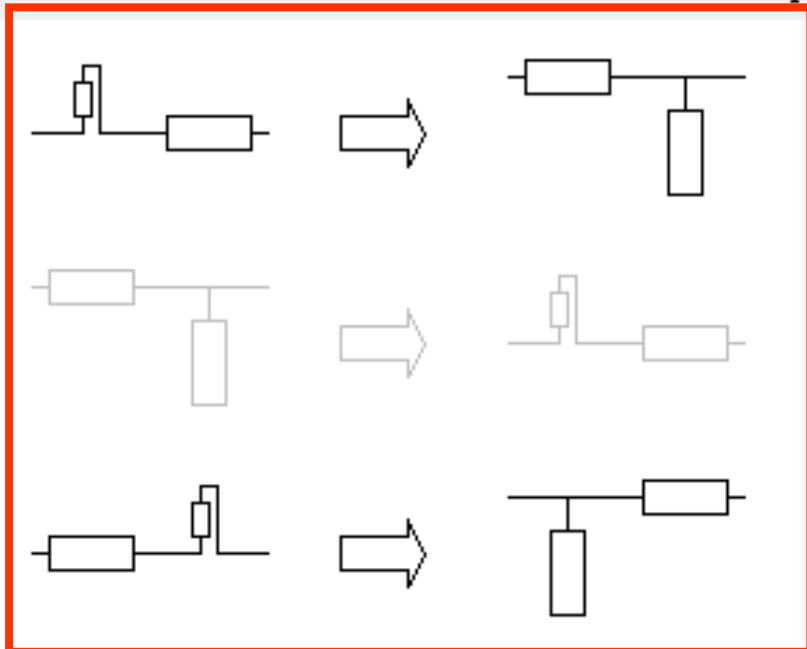

Add Transmission Lines

Before Network

After Network

Microstrip Substrate

h = 30 mil

Er = 3

Transform Undo OK Cancel Help

添加单元器件后的滤波器原理图

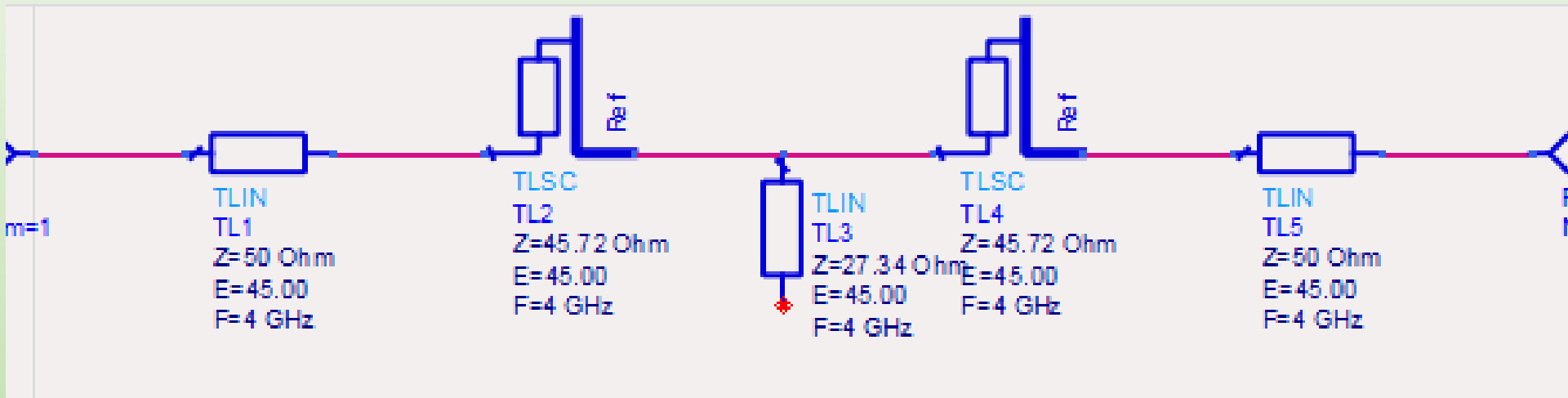

➤ 选中一组 → 【Add】 → 【Transform】

➤ 选中另一组，同样操作

- LC to TLine
- TLine to TLine (Kuroda)
- LC, TLine to Microstrip

Component Selection

TL4 TL5

TL4 TL5

Add

Add All

Cut

Unit Element (45 deg)

Zo = 50

Ohm

Transform

Undo

OK

Cancel

Help

Left-click return arrow to return to main transform panel

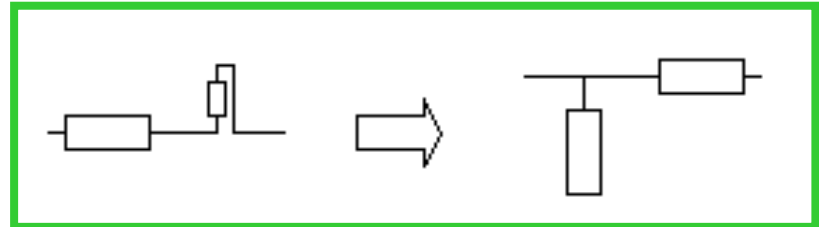
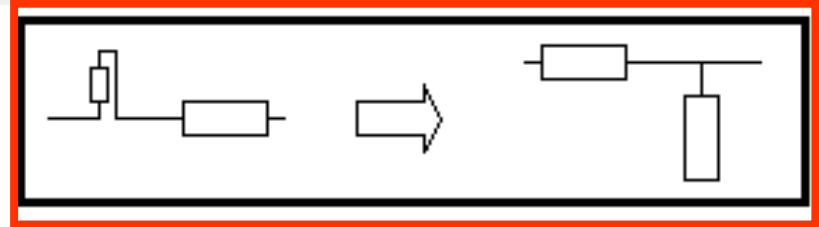

Add Transmission Lines

Before Network

After Network

Microstrip Substrate

h = 30 mil

Er = 3

用Kuroda恒等式转换后的滤波器原理图

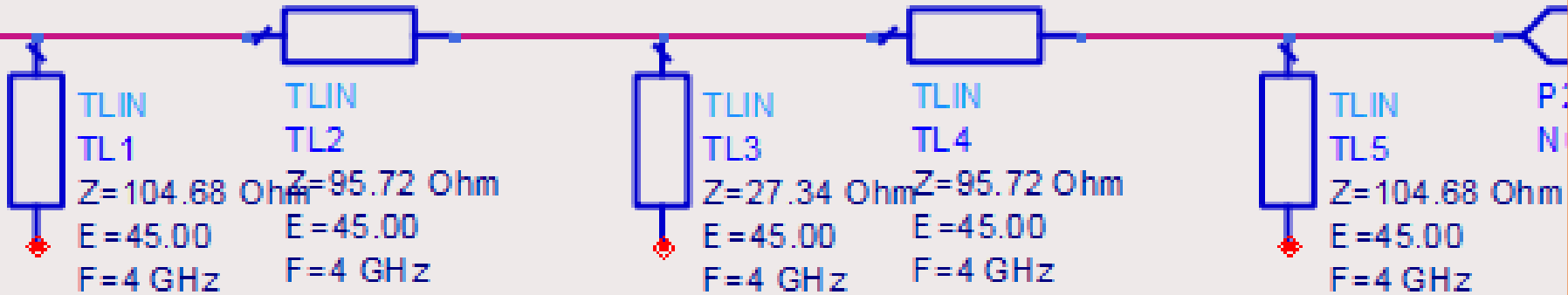

➤ 选中“LC, Tline to Microstrip”，单击短截线图标，单击【Add All】

LC, TLine to Microstrip

Component Selection

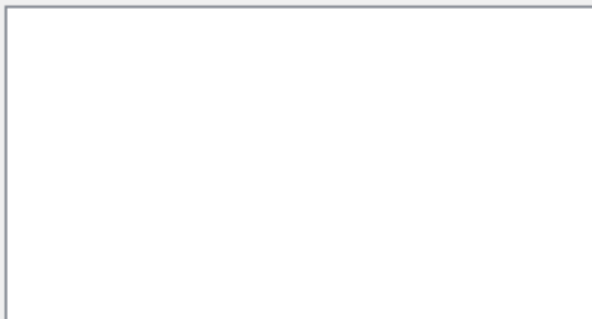

Add

Add All

Cut

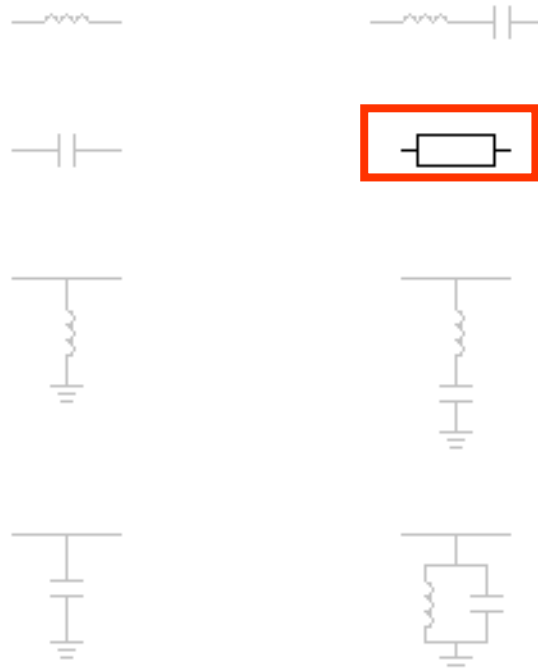

Add Transmission Lines Microstrip Substrate

➤ 设置基片厚度30mil，介电常数4.4 → 【Transform】 → 【OK】

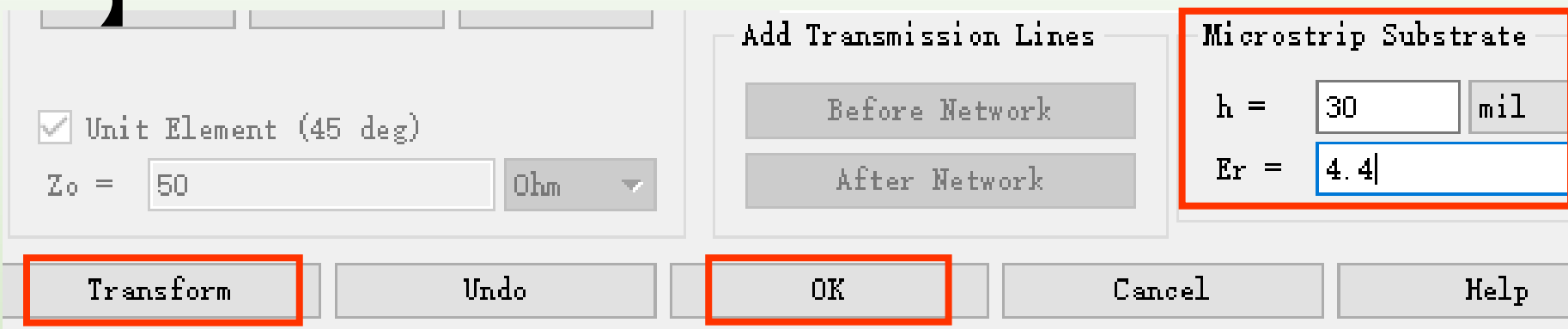

➤ 在原理图中，选中DT1，单击  最终的电路

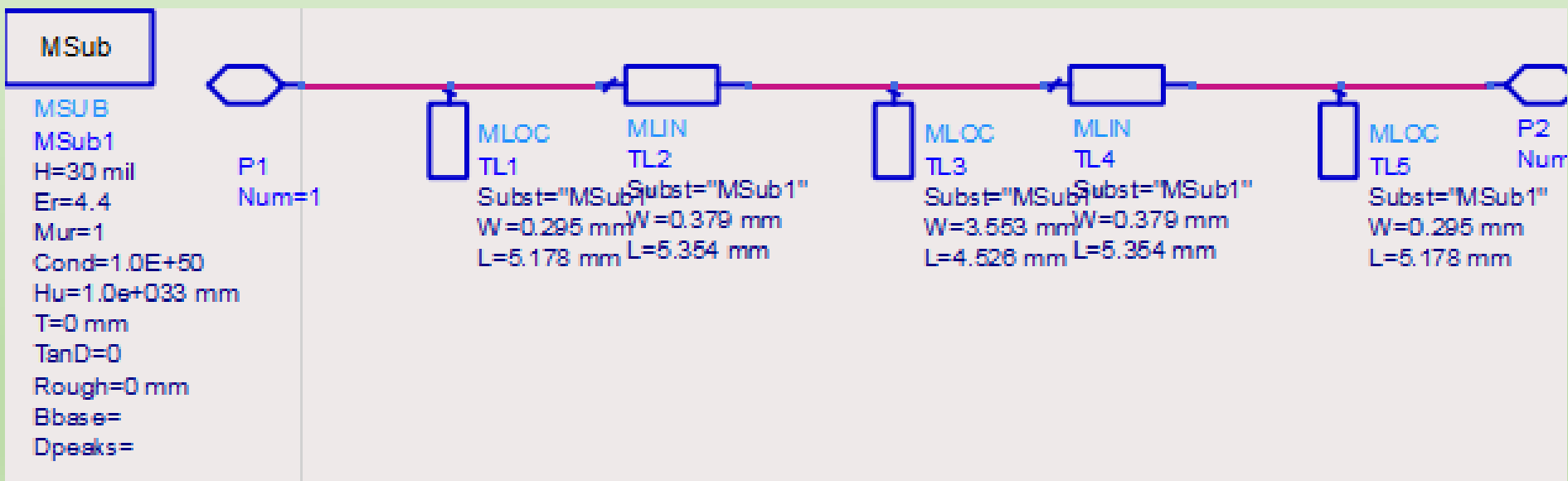

➤ 单击  返回

最终的仿真结果

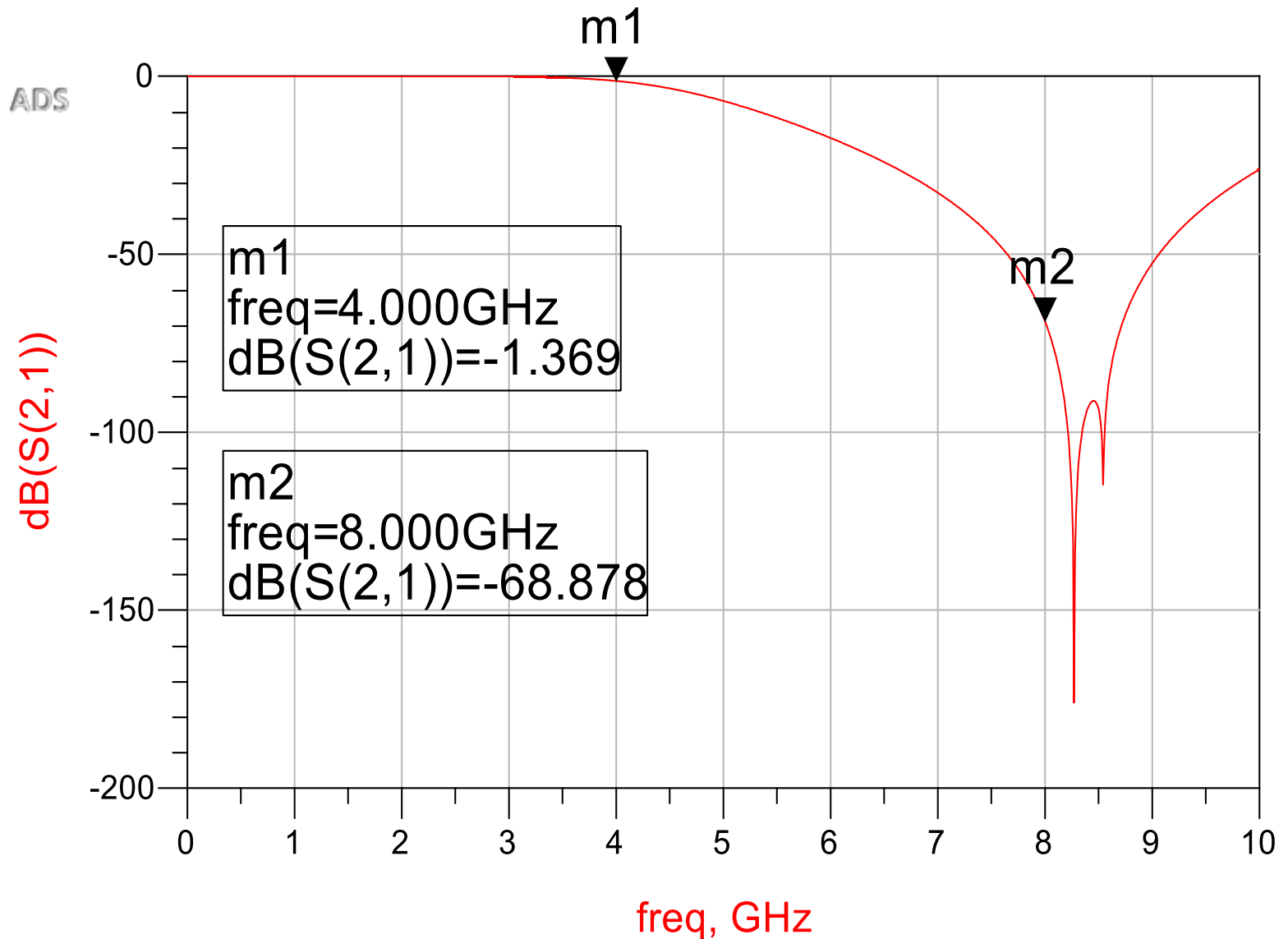

- 执行菜单命令【Layout】→【Generate/Update Layout】，弹出一个设置对话框，这里应用其默认设置，直接单击OK

仿真电路板（原理图增加50Ω微带线TL1、TL2

